

光學系統設計 (Optical System Designs - 9)

陳志隆教授

交通大學光電工程學系/光電工程研究所
電子與資訊研究中心

Email: jlchern@faculty.nctu.edu.tw

Blog: <http://osdman.spaces.live.com/>

12252007	改版	JLC
02172008	Second version	JLC

課程總目錄

幾何光學集要： 完美成像與高斯光學、像差理論估算與案例分析	第一週
物理光學集要：繞射、點分散函數、MTF、偏振、高斯光束、 部份同調與散射	第二週
鏡組最佳化分析及簡例說明	第三週
公差容忍度分析與光學測試及簡例說明	第四週
非球面鏡頭理論、設計與案例說明	第五週
投影鏡頭理論、設計與案例說明	第六週
變焦鏡頭理論、系統設計與案例說明	第七週
相機鏡頭設計與案例說明	第八週
鏡頭設計、資料庫與專利深論	第九週
非傳統鏡頭系統之設計與案例說明	第十週



課程總目錄（續）

照明基礎理論與光通量(throughput)估算	第十一週
色彩學 (colorimetry) 與應用	第十二週
照明光源與典型照明工法 (schemes)	第十三週
照明光學設計法I:反射片 (reflectors)	第十四週
照明光學設計法II: Condenser and lenslet arrays	第十五週
照明光學設計法III:光管 (lightpipe)	第十六週
照明光學設計法IV: Fresnel lenses	第十七週
照明應用實例與解析	第十八週

第九講大綱

- Patent and optical design
- Patent resource
- Issues of patent literature
- How to analyze patent
- Example of Patent analysis
- Useful patent selection
 - Caldwell selection and LensView
- Examples
- Conclusions
- Homework

Patent and optical designs

Optical Design Tasks

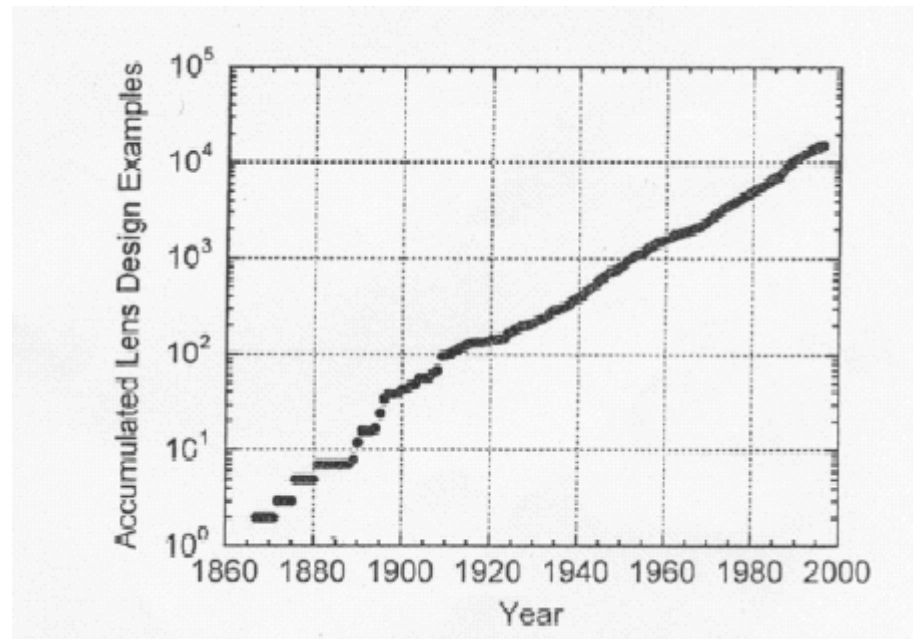
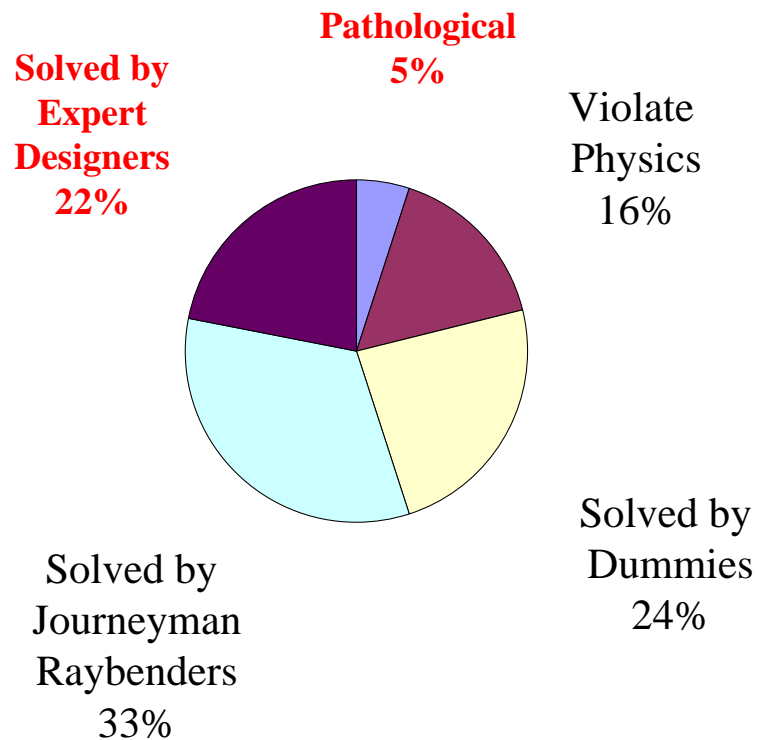

OPN (1997)

From Sinclair

Patent resources and issues

- US patents:
 - <http://www.uspto.gov>
- Japan patents:
 - <http://www.jpo-miti.go.jp>
- W. J. Smith
 - Modern Lens Design (McGraw-Hill, 1992)
- M. Laikin
 - Lens Design (3rd. Marcel-Dekker, 2001)
- J. B. Caldwell
 - “Patent design of the month” (OPN, Jan. 1997-Aug. 2000)
- LensVIEW
- Software packages (OSLO/ Code V/ Zemax’s Zbase)

- Issues:
 - IP
 - Data validity
 - For time to time, there is no
 - Lens apertures/vignetting
 - Many omit
 - Field of view
 - Some omit
 - F-number
 - Still,
 - typographical errors
 - Data scaling
 - Usually, scaled with focal length, such that focal length is 1, 10, or 100
 - This can’t be done for afocal system, so scaled to exit pupil (such that exit pupil is 10 or something like that)

US paten web entrance

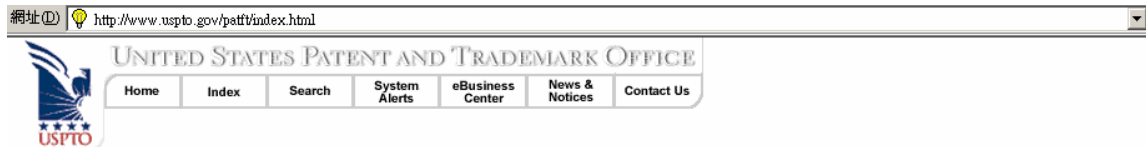

Patent Full-Text and Full-Page Image Databases

Issued Patents (PatFT) (full-text since 1976, full-page images since 1790)	Published Applications (AppFT) (published since 15 March 2001)
<ul style="list-style-type: none"> ● Quick Search ● Advanced Search ● Patent Number Search ● Operational Notices and Status ● Database Contents ● Help 	<ul style="list-style-type: none"> ● Quick Search ● Advanced Search ● Publication Number Search ● Operational Notices and Status ● Help

Field Code	Field Name	Field Code	Field Name
PN	Patent Number	IN	Inventor Name
ISD	Issue Date	IC	Inventor City
TTL	Title	IS	Inventor State
ABST	Abstract	ICN	Inventor Country
ACLM	Claim(s)	LREP	Attorney or Agent
SPEC	Description/Specification	AN	Assignee Name
CCL	Current US Classification	AC	Assignee City
ICL	International Classification	AS	Assignee State
APN	Application Serial Number	ACN	Assignee Country
APD	Application Date	EXP	Primary Examiner
PARN	Parent Case Information	EXA	Assistant Examiner
RLAP	Related US App. Data	REF	Referenced By
REIS	Reissue Data	FREF	Foreign References
PRIR	Foreign Priority	OREF	Other References
PCT	PCT Information	GOVT	Government Interest
APT	Application Type		

US patents

- The class we concerned
 - 359
 - Optics: systems (including communication) and elements
 - ccl/359/\$
 - Example: 359/708-719
 - » With aspheric subclasses
 - Example: 359/642
 - » lens

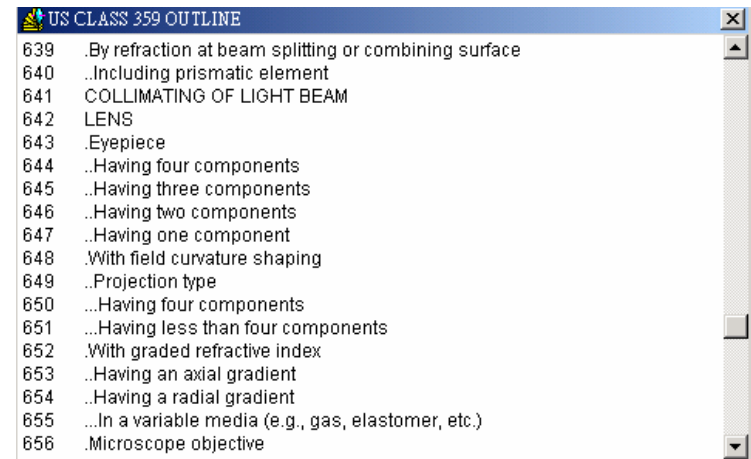
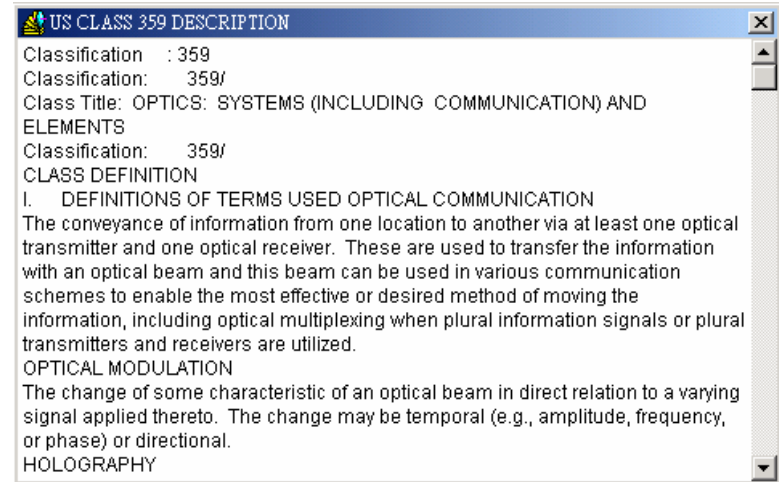

Patent format



US 20030052972A1

(19) **United States**
(12) **Patent Application Publication** (10) **Pub. No.: US 2003/0052972 A1**
Tanaka et al. (43) **Pub. Date: Mar. 20, 2003**

(54) **DIGITAL STILL CAMERA CAPABLE OF TELECOMMUNICATION**

(30) **Foreign Application Priority Data**

Jun. 30, 1997 (KR)..... 97-29444

(76) Inventors: **Masahide Tanaka**, Osaka (JP);
Katsutoshi Ito, Tokyo (JP)

Publication Classification

Correspondence Address:
McGuireWoods LLP
Suite 1800
1750 Tysons Boulevard
McLean, VA 22102 (US)

(51) **Int. Cl.⁷** **H04N 5/225**
(52) **U.S. Cl.** **348/207.1**

(57) **ABSTRACT**

(21) Appl. No.: **10/285,423**
(22) Filed: **Nov. 1, 2002**

A digital still camera capable of telecommunication includes a device which converts an optical image into a digital electromagnetic signal indicative of a still image, a receiver which receives an electromagnetic signal generated in accordance with a wireless telephone system, a modifying unit which modifies the electromagnetic signal into a digital electronic signal indicative of a still image, and for a device which alternatively displays a still image on the basis of the digital electronic signal from the converting device or from the modifying unit

Related U.S. Application Data

(63) Continuation of application No. 09/025,862, filed on Feb. 19, 1998.

- Abstract
 - How many claims (and drawings)
- Field
- Background
- Summary
- Brief description of the drawings
- Detailed description of preferred embodiment

Learning from patent: keys

1. Not just read the examples!
2. Check claims and drawing carefully
3. Think more, after reading abstract and summary
4. You can learn a lot from “background” to get an idea of current trend
5. Reproduce/check the results from embodiments
It may take a long time to reproduce
6. Do roadmap

Key 1: check claims and drawing

OTHER PUBLICATIONS

Optical Design-Military Standardization Handbook MIL-HDBK-141 (Defense Supply Agency, Washington, D.C., 1962), p. 14-1.

W. J. Smith, *Modern Optical Engineering Second Ed.* (McGraw-Hill, Inc., New York, 1990), pp. 404-407.

diffracting surface and a convex refracting surface, an equi-convex element having two refracting convex surfaces and a second refracting/diffracting element having a diffracting surface and a convex refracting surface.

15 Claims, 5 Drawing Sheets

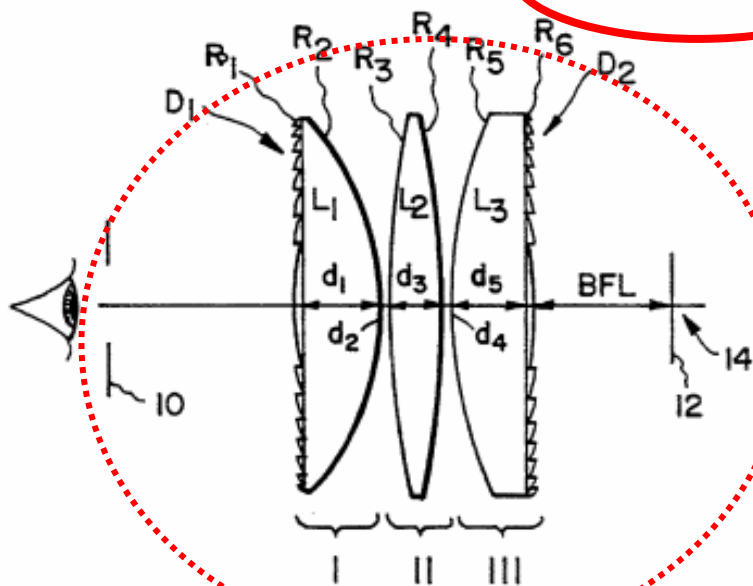

In the first page, the most important drawing will be reproduced.

Claims

You have to say something like this!!!

the drawings, the present invention is applicable to a camera where the photo filmstrip is wound up onto the take-up spool one frame after each exposure. In that case, the gear holding plate portion may be located above a film take-up chamber that is located on the opposite side from a cartridge chamber, to hold a gear mechanism for rotating a take-up spool.

Thus, the present invention is not to be limited to the above embodiment but, on the contrary, various modifications will be possible to those skilled in the art without departing from the scope of claims appended hereto.

What is claimed is:

1. A camera comprising a finder optical system and a film transport gear mechanism, said camera comprising:
 - a finder frame holding said finder optical system and at least light emitting and receiving sections of an auto-focus device;
 - a gear holding plate formed integrally with said finder frame, said gear holding plate holding gears of said film transport gear mechanism rotatably; and
 - a slit formed between said finder frame and said gear holding plate.
2. A camera as recited in claim 1, wherein said film transport gear mechanism is disposed on an upper portion of an internal body frame of said camera with top ends of said gears held by said gear holding plate.
3. A camera as recited in claim 2, wherein said film transport gear mechanism is provided for rotating a spool of

a film cartridge as loaded in a cartridge chamber of said camera, and disposed atop said cartridge chamber.

4. A camera as recited in claim 2, wherein said finder frame and said gear holding plate are mounted atop said internal body frame of said camera, and secured to said internal body frame by screws on opposite sides of said slit.
5. A camera as recited in claim 4, further comprising a zoom lens and a zoom flash device, wherein a flash projector of said zoom flash device is mounted on a top side of said gear holding plate such that said flash projector is movable back and forth to change a distance to a condenser lens of said zoom flash device, and wherein said slit doubles as a guide slit for said flash projector.
6. A camera as recited in claim 5, wherein said flash projector is engaged via said slit with an interconnection mechanism disposed below said finder frame, said interconnection mechanism transmitting zooming motion of said zoom lens to said flash projector.
7. A camera as recited in claim 6, wherein said finder optical system are mounted movable on said finder frame, to constitute a zooming viewfinder.
8. A camera as recited in claim 1, wherein a photometry device for measuring a subject brightness and a red-eye reduction light projecting device are mounted on said finder frame.

* * * * *

Key 2: Look at Abstract and summary

The wording is somehow a little different from common use!!!

(57) ABSTRACT

A digital still camera capable of telecommunication includes a device which converts an optical image into a digital electromagnetic signal indicative of a still image, a receiver which receives an electromagnetic signal generated in accordance with a wireless telephone system, a modifying unit which modifies the electromagnetic signal into a digital electronic signal indicative of a still image, and for a device which alternatively displays a still image on the basis of the digital electronic signal from the converting device or from the modifying unit

SUMMARY OF THE INVENTION

In view of the foregoing, an object of the present invention is to provide a compact camera, wherein a finder frame and a gear holding plate are formed as an integral part to reduce the number of parts of the camera and thus make the camera more compact and low cost, but the influence of

[57]

ABSTRACT

Eyepiece optical systems having arrangements of surfaces where light is refracted or diffracted provide eyepieces with fewer elements and more compact designs than comparable, conventional eyepiece designs. These

systems have three elements each with power, and provide a wide field-of-view and an eye relief of approximately equal to the focal length of the eyepiece. One embodiment (the eye side) a refracting, meniscus, with a surface concave toward the eye, it having a refracting convex surface and a refracting convex surface, and a refracting doublet element with a refracting convex surface and a refracting convex surface (each element being a refracting doublet having a refracting convex surface and a refracting convex surface).

Another embodiment, from the eye side, a refracting doublet having a refracting convex surface and a refracting convex surface, and a refracting doublet having a refracting convex surface and a refracting convex surface.

3. Learning more from background

More on abstract

(57)

ABSTRACT

A film transport gear mechanism is mounted on an upper portion of an internal body frame of a camera, and held rotatably from the top by a gear holding plate (51). The gear holding plate is integrally formed with a finder frame (50) that holds a viewfinder optical system, light emitting and receiving sections (48, 49) of an autofocus device and a photometry device (54) thereon. A slit (75) is formed between the gear holding plate and the finder frame, so the gear holding plate and the finder frame are interconnected merely through narrow connecting portions (76, 77). Warps and deformations in the gear holding plate are absorbed into the slit and not transmitted to the finder frame.



BACKGROUND OF THE INVENTION

1. Field of the Invention

The present invention relates to a compact camera, and more particularly to an improvement in the camera that reduces the number of parts of the camera and makes the camera more compact and low cost, without damaging the performance of the camera.

2. Background Arts

Reducing both the manufacturing cost and the size of the compact camera has been continually searched for. For this purpose, devices for uniting components of the camera to reduce the number of parts and the number of manufacturing processes have conventionally been developed. When uniting any components, functions of these components and the requisite accuracy are taken into consideration. For example, concerning light emitting and receiving sections of an autofocus device, or a viewfinder optical system, as they require accuracy in positioning, elements of these components are mounted in an integral frame to constitute an united finder assembly. Then, the finder assembly is attached to the top of an internal body frame of the camera.

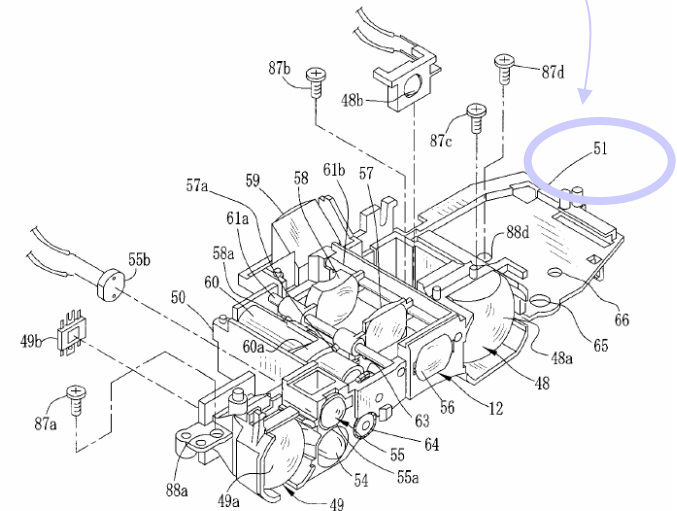

Indicate why the invention is important!!!!

4. Look at embodiments

BRIEF DESCRIPTION OF THE DRAWINGS

The above and other objects and advantages of the present invention will become apparent from the following detailed description of the preferred embodiments when read in association with the accompanying drawings, which are given by way of illustration only and thus are not limiting the present invention. In the drawings, like reference numerals designate like or corresponding parts throughout the several views, and wherein:

→ FIG. 1 shows a perspective view of a compact zoom camera according to an embodiment;

DETAILED DESCRIPTION OF THE EMBODIMENTS

→ As shown in FIGS. 1 and 2, a camera embodying the present invention has a camera body consisting of an internal body frame 2 on which mechanical and electronic elements are mounted, and front and rear covers 3 and 4 covering the front and rear of the internal body frame 2.

How to analyze patent?

- In patent literature, neither specification nor prescription available, usually
 - In lens design, somehow, these will be included, though
 - What should we get?
 - Read figures closely
 - Classification by optical specification
 - See What LensView does?!
 - A good reference
- In reality,
 - If you feel it is important, then just read it “again and again”!!
 - Try to reproduce it by what ever you can do
 - Simulation is a good approach
 - You need to make an inverse engineering
 - Produce a simulation model to reproduce the key features
 - You need to have a platform for development

How to build up patent roadmap

- Build up previous works from references
- Check further citation from patent database

Example:

Non-Canon's patent Canon's patent

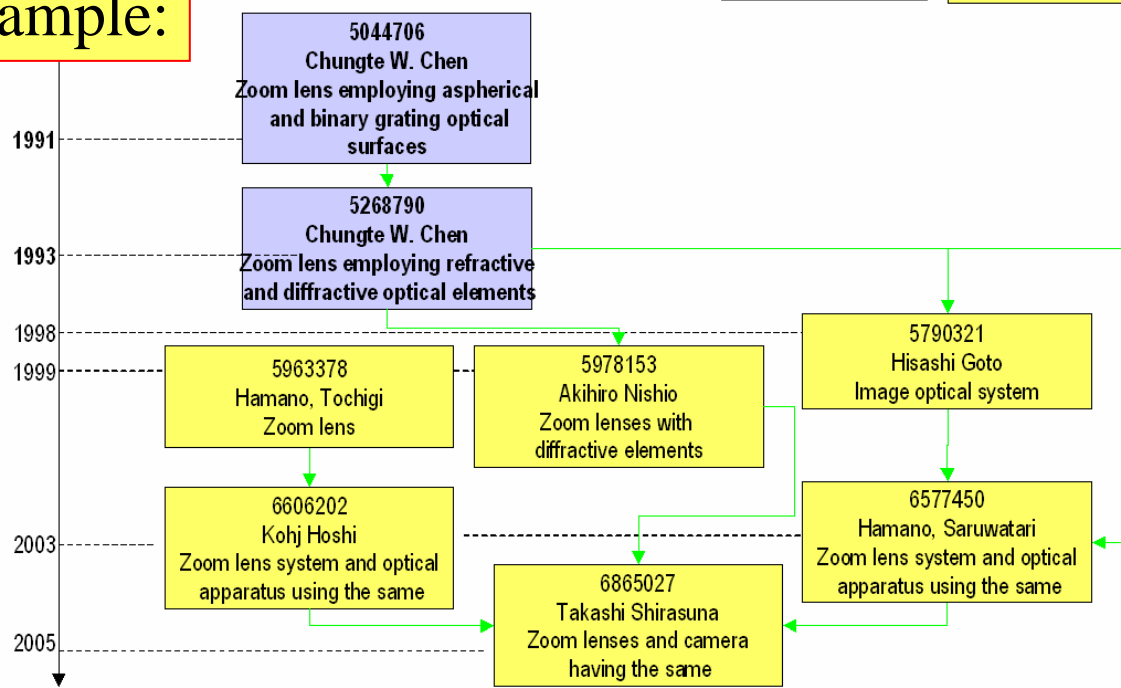

(56)

References Cited

U.S. PATENT DOCUMENTS

5,128,842	A *	7/1992	Kenmochi	362/31
5,339,179	A *	8/1994	Rudisill et al.	349/65
5,521,796	A *	5/1996	Osakada et al.	362/31
5,838,403	A *	11/1998	Jansson et al.	349/65
5,926,601	A *	7/1999	Tai et al.	349/64
5,961,198	A *	10/1999	Hira et al.	362/31
5,980,054	A *	11/1999	Fukui et al.	362/31
6,139,162	A *	10/2000	Masaki	362/31
6,164,799	A *	12/2000	Hirmer et al.	362/330
6,231,200	B1 *	5/2001	Shinohara et al.	362/31
6,241,358	B1 *	6/2001	Higuchi et al.	362/31

Patent analysis 1: Canon works

- There are around 30000 patents in past 20 years (from 1985 to 2005) assigned by Canon

USPTO PATENT FULL-TEXT AND IMAGE DATABASE



Searching 1976 to present...

Results of Search in 1976 to present db for:

AN/Canon: 29983 patents.
Hits 1 through 50 out of 29983

Next 50 Hits

Jump To

Refine Search AN/Canon

PAT. NO. Title

- 6,877,125 Devices and methods for estimating a series of symbols
- 6,876,826 Electrophotographic image forming apparatus having detachable process cartridge
- 6,876,825 Image forming apparatus capable of executing image forming jobs having priority levels

With the helps of CY Liu

After 1998, the number exceeds 2000

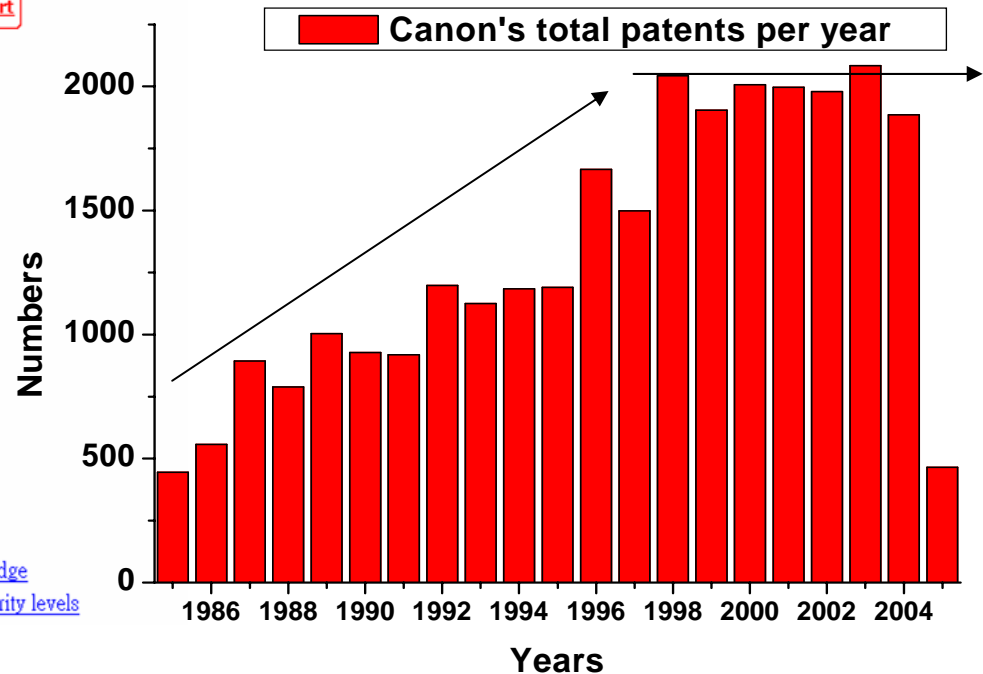

Canon's Patents of CCL 359

Searching 1976 to present...

Results of Search in 1976 to present db for:
(AN/Canon AND CCL/359/\$): 1829 patents.
Hits 1 through 50 out of 1829

Next 50 Hits

Jump To

Refine Search

AN/Canon AND ccl/359/\$

PAT. NO. Title

- 1 [6,876,476](#)  [Display device and process for production thereof](#)
- 2 [6,873,463](#)  [Diffractive optical element and optical system having the same](#)
- 3 [6,873,451](#)  [Electrophoretic display device and method for driving the same](#)

There are ~ 2000 patents in optical design (from 1985 to 2005)

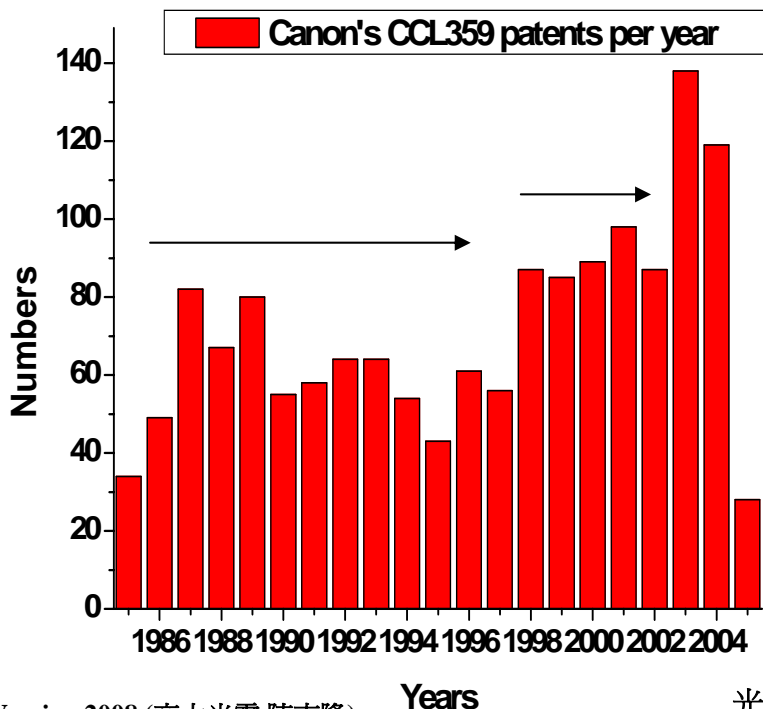

Patents of CCL 362

There are 100 patents in illumination design (form 1985 to 2005)

Searching 1976 to present...

Results of Search in 1976 to present db for
(AN/Canon AND CCL/362/\$): 99 patents.

Hits 1 through 50 out of 99



Next 50 Hits

Jump To

Refine Search

AN/Canon AND ccl/362/\$

PAT. NO. Title

- 1 [6,868,223](#)  [illumination apparatus, exposure apparatus using the same and device fabrication method](#)
- 2 [6,863,419](#)  [illumination optical system, image display optical system, projection type image display apparatus, and image display system](#)
- 3 [6,857,764](#)  [illumination optical system and exposure apparatus having the same](#)

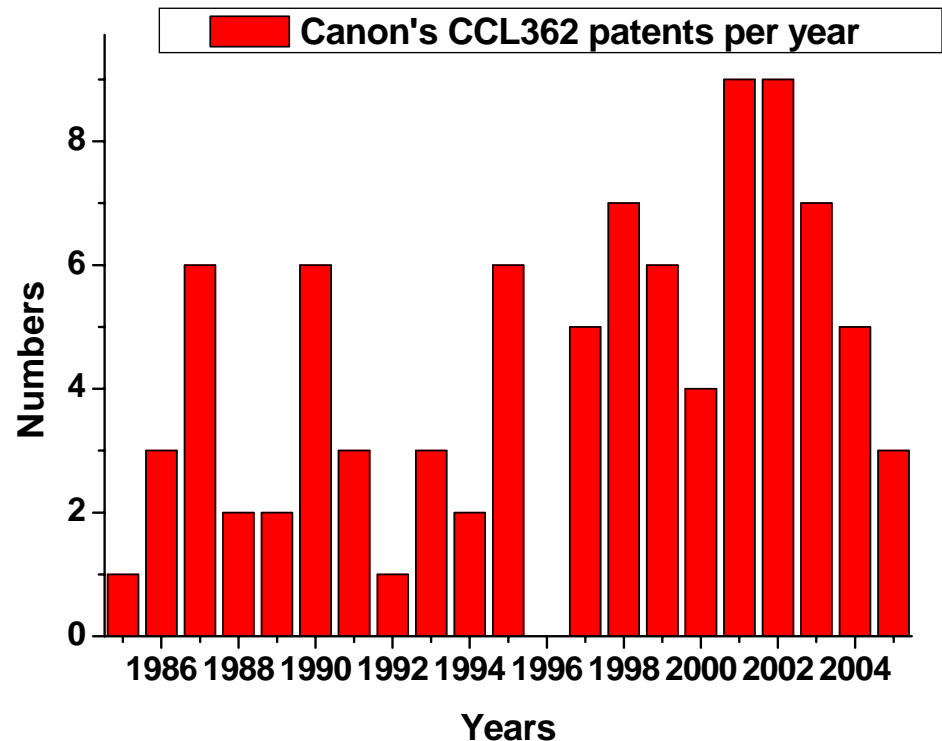

Subjects: Zoom lenses design

Searching 1976 to present...

Results of Search in 1976 to present db for:
(((AN/Canon AND "zoom lenses") AND CCL/359/\$) AND ISD/19850101->20051231): 321 patents.

Hits 1 through 50 out of 321

Next 50 Hits

Jump To

Refine Search

AN/Canon AND "zoom lenses" AND CCL/359/\$ AND isd/1/1/1985->12,

PAT. NO. Title

1	6,867,916	Viewfinder o
2	6,865,027	Zoom lens an

- Herein, I concentrate my topic on “zoom lenses” design
- It can be found that in past twenty years, there are 321 patents
 - I search the latest patent for doing patent roadmap
 - The patent number is 6865027
 - The topic is “Zoom lenses and camera having the same”, Invented by Japanese

The trend of zoom lens design

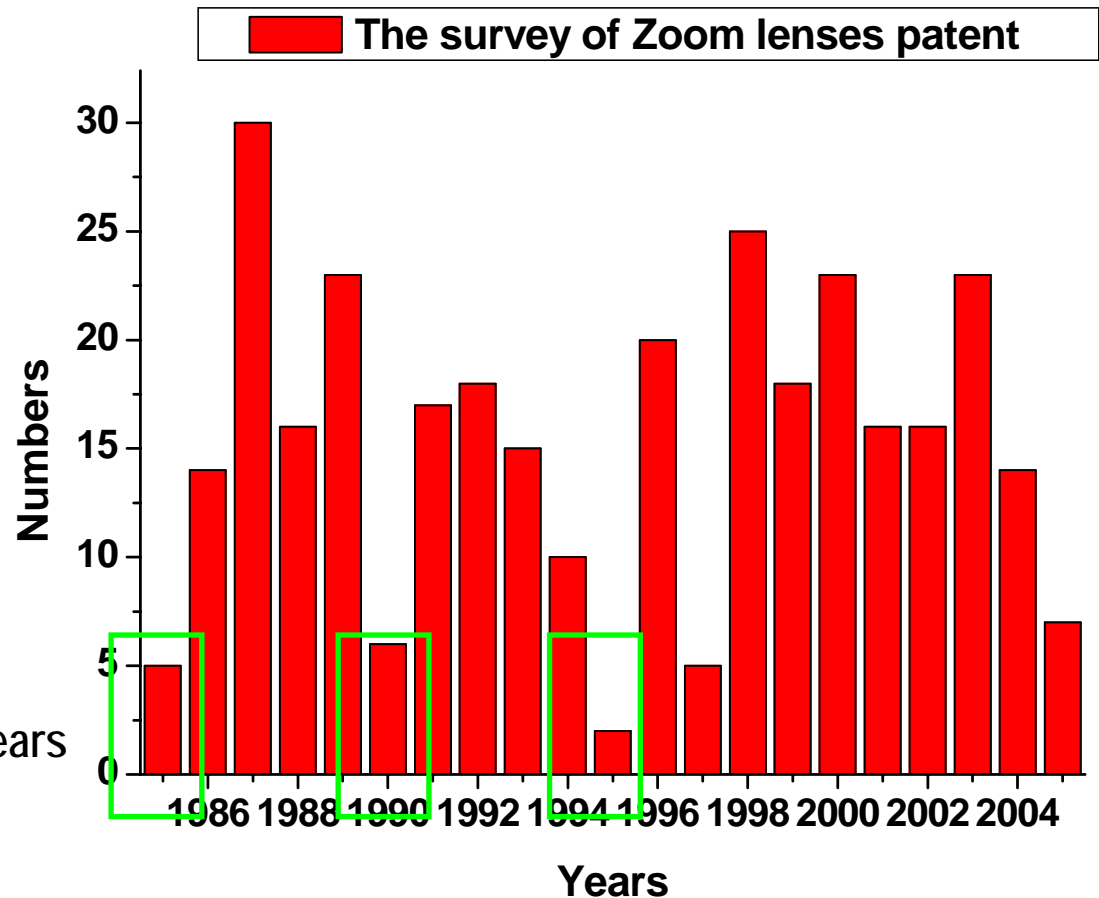

- The trends of zoom lens design is stable
- 15 patents per year
- There is a minimum every 5 years
- It is more stable in recent years

Show how to do Patent check

(12) **United States Patent**
Rizkin et al. (10) **Patent No.:** **US 6,814,470 B2**
(45) **Date of Patent:** **Nov. 9, 2004**

(54) **HIGHLY EFFICIENT LED LAMP**
(75) Inventors: **Alexander Rizkin**, Redondo Beach, CA (US); **Robert H. Tudhope**, Rancho Palos Verdes, CA (US)
(73) Assignee: **Farlight LLC**, Wilmington, CA (US)
(*) Notice: Subject to any disclaimer, the term of this patent is extended or adjusted under 35 U.S.C. 154(b) by 0 days.

(21) Appl. No.: **10/316,642**
(22) Filed: **Dec. 11, 2002**
(65) **Prior Publication Data**
US 2003/0137838 A1 Jul. 24, 2003

Related U.S. Application Data

(63) Continuation-in-part of application No. 10/277,230, filed on Oct. 21, 2002, which is a continuation-in-part of application No. 09/566,521, filed on May 8, 2000, now Pat. No. 6,543,911.
(51) **Int. Cl.**⁷ **F21V 5/00**
(52) **U.S. Cl.** **362/327; 362/240; 362/245; 362/800**
(58) **Field of Search** **362/240, 241, 362/243, 244, 800, 327, 329, 245; 359/718**

(56) **References Cited**
U.S. PATENT DOCUMENTS
2,215,900 A * 9/1940 Bitner 362/309
5,775,792 A * 7/1998 Wiese 362/328
6,402,347 B1 * 6/2002 Maas et al. 362/294
6,547,423 B2 * 4/2003 Marshall et al. 362/333

* cited by examiner
Primary Examiner—Alan Cariaso
Assistant Examiner—Ali Alavi
(74) *Attorney, Agent, or Firm*—Gehrke & Associates, S.C.

(57) **ABSTRACT**
A highly efficient LED lamp includes an optical module and a housing. The optical module has at least one light emitting diode (LED) that emits light with a wide divergence, a non-imaging optical (NIO) element and a transparent window. The NIO element includes a refractive member located around a LED optical axis and a total internal reflection member located around the refractive member. The refractive member and the total internal reflection member are integrated in a single transparent element having a mutual focal point, wherein the NIO element collects a significant amount of light emitted by the LED with wide divergence located at the focal point, to compress the collected light with high efficiency into a beam with a generally different angular spread in a horizontal plane and a vertical plane and to direct the compressed light outside of the lamp.

16 Claims, 4 Drawing Sheets

With the helps of CC Chen

Key Figure and Figures

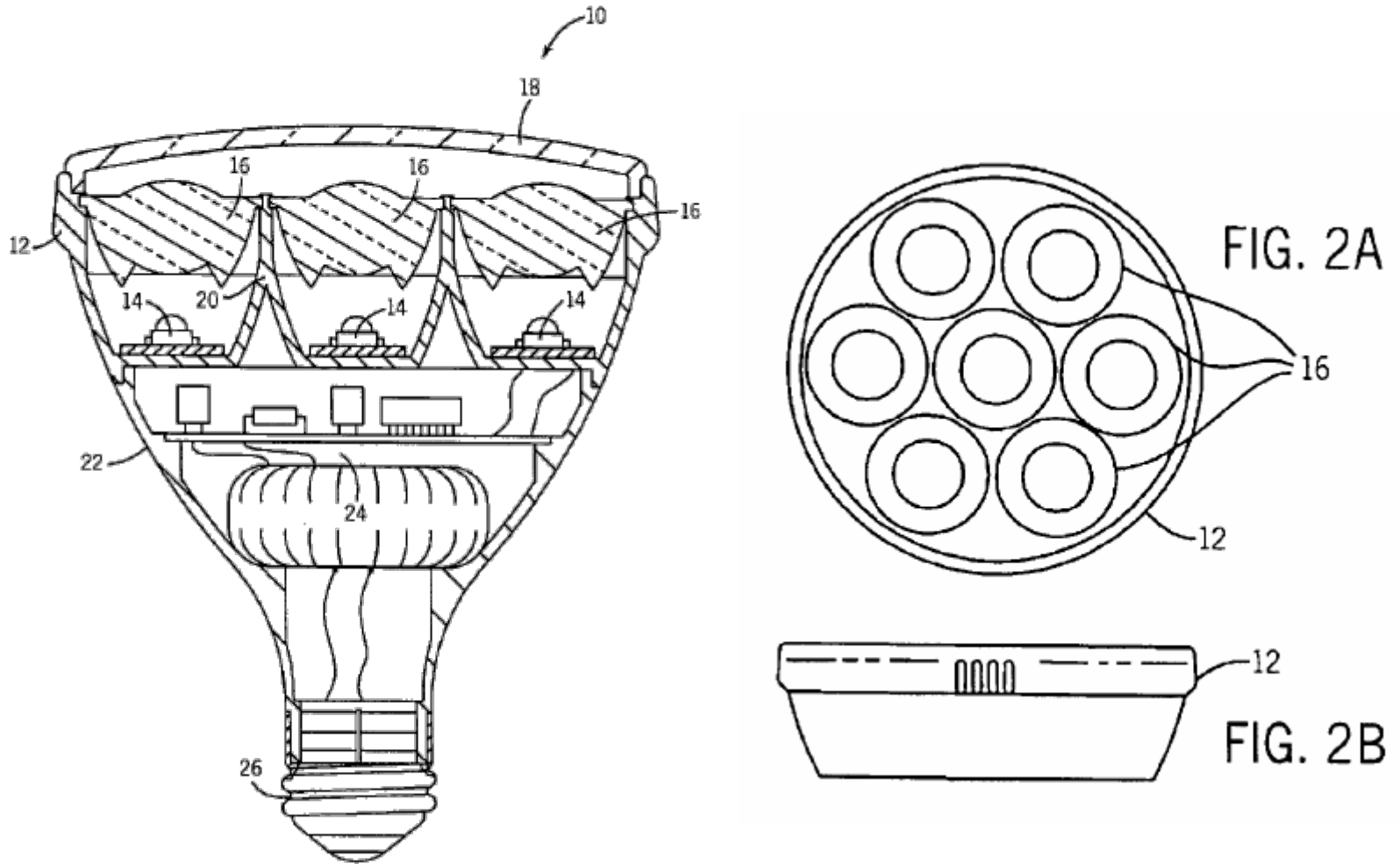

Road Map

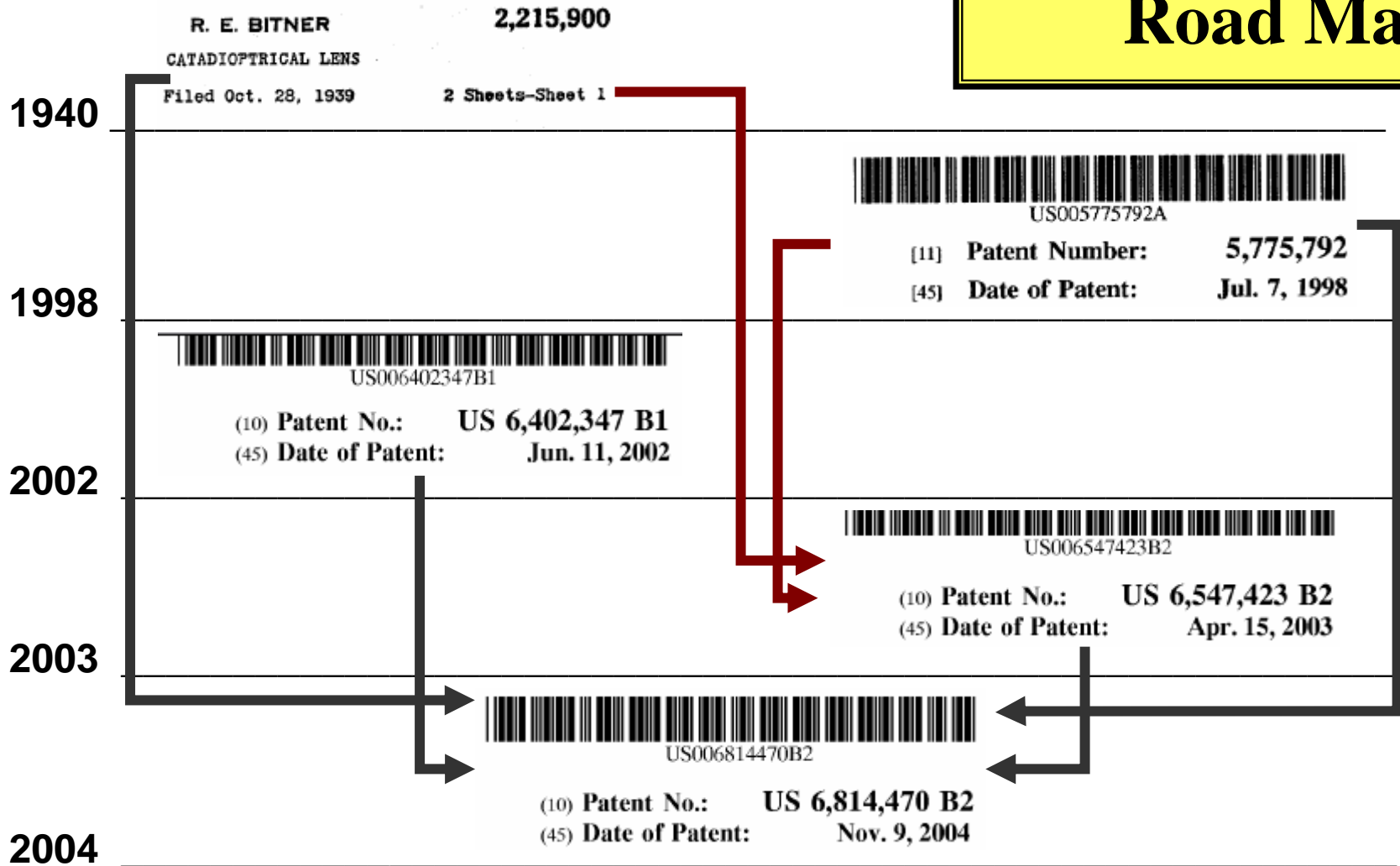

Road map with key figure

1940

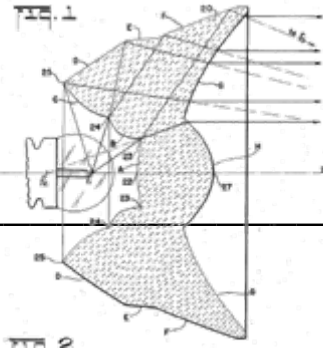

1998

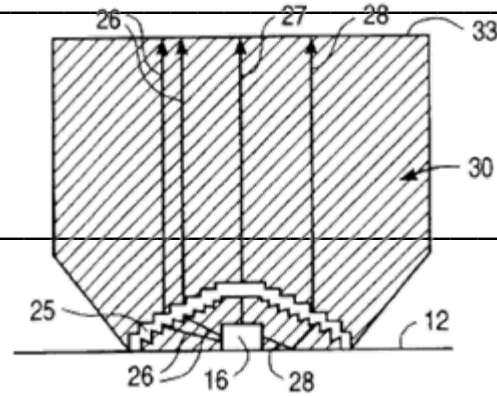

2002

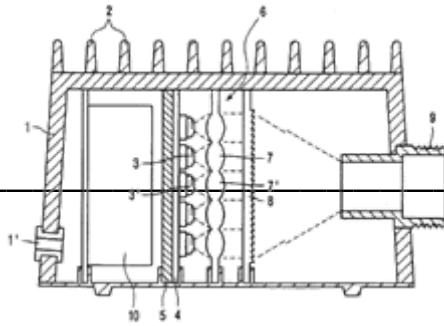

2003

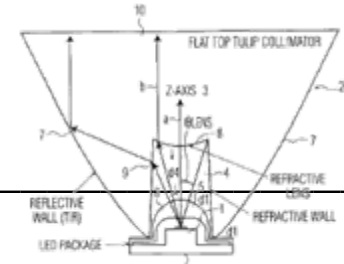

2004

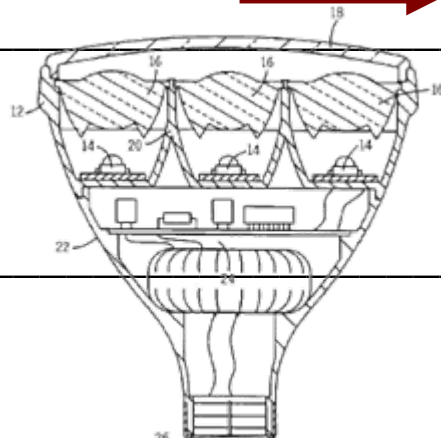

Simple simulation by OSLO

- Using OSLO to estimate the center lens
 - Set it as a equal-convex lens with conic surface.
- Thickness is 15 mm and the distance between the focal point to first surface is 7 mm
 - using spot size is minimum to solve the radius and conic constants .
 - Results:
 - $R=10.4562814166115$
 - $CC= -1.8572884775762$

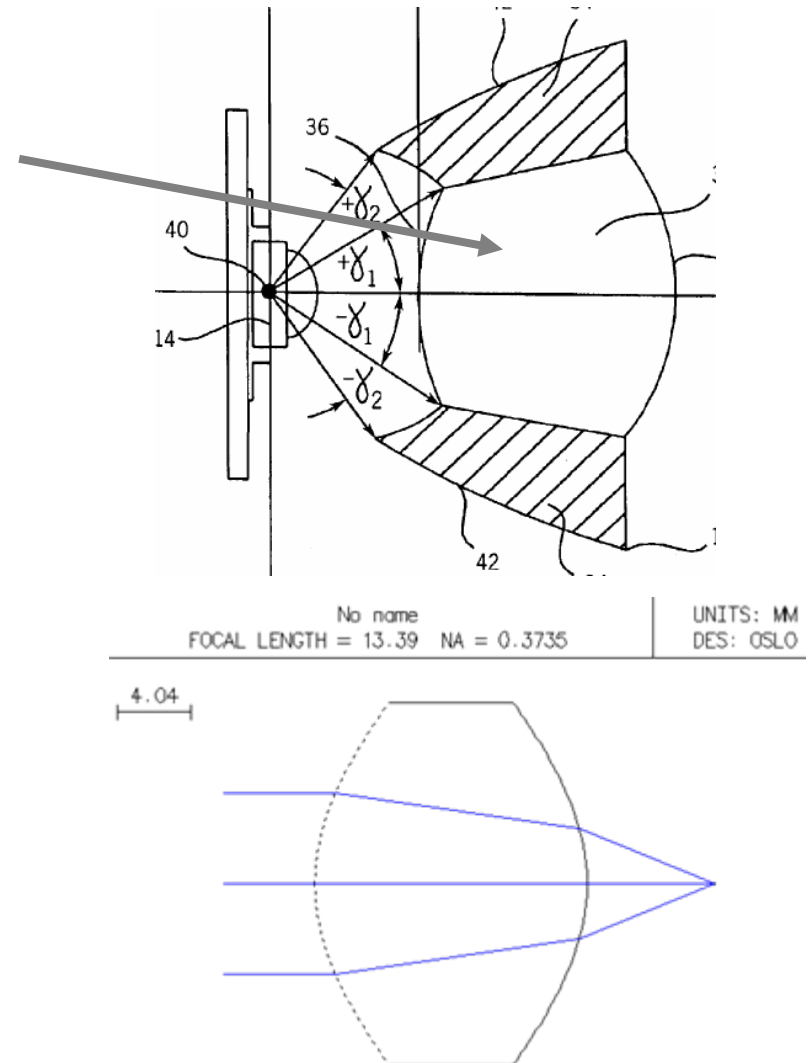

Simple simulation by TracePro

- Making a parabolic lens
 - Radius is 6mm/ length is 20mm/material is BK7/aperture is 33.4/Conic constant is -1
 - set the origin as the focus of parabola.
- Making a sphere with radius is 10mm and center is at origin.
- 3. Boolean operation:subtract 1 and 2.
- 4. Unite 3 and the center lens made by OSLO.

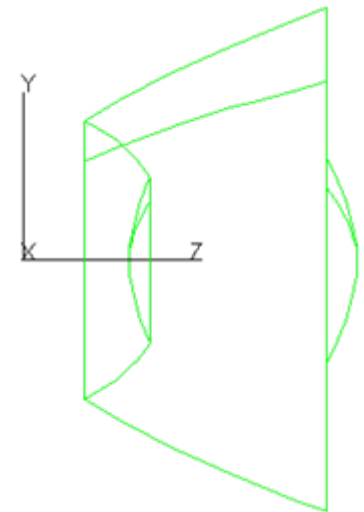
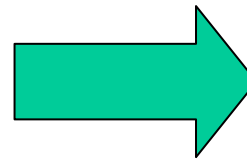
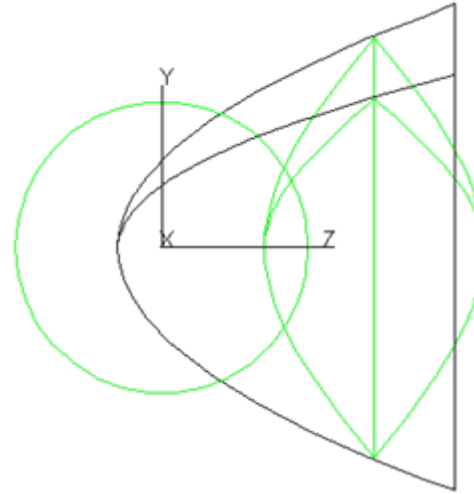

Estimate the efficiency (%)

The distance between the screen and origin is 25 m and the size is 4m x 4m

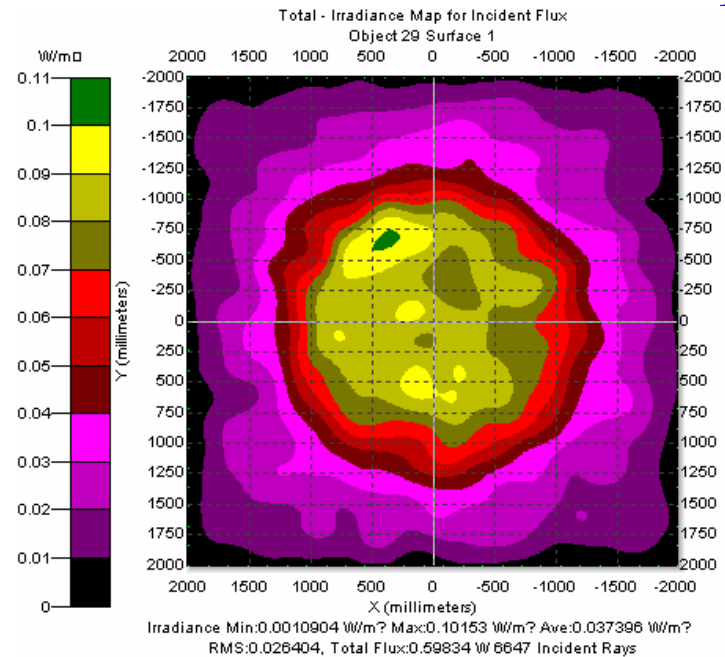
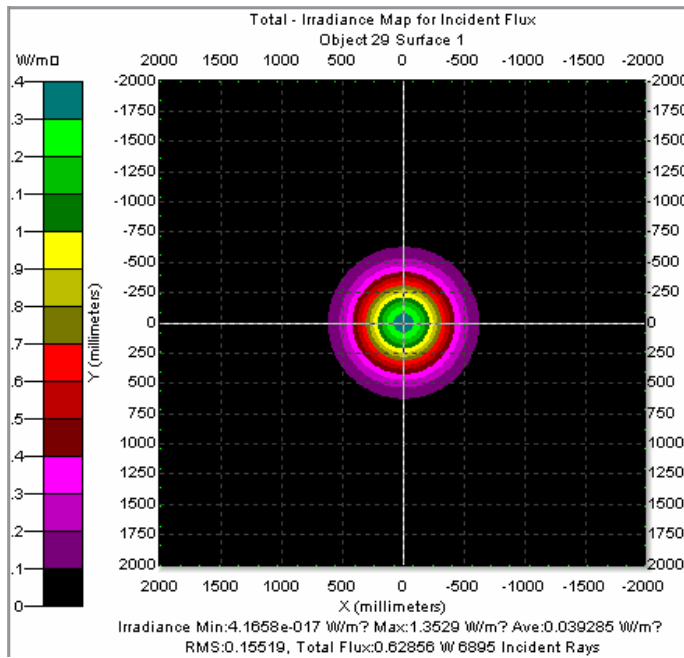
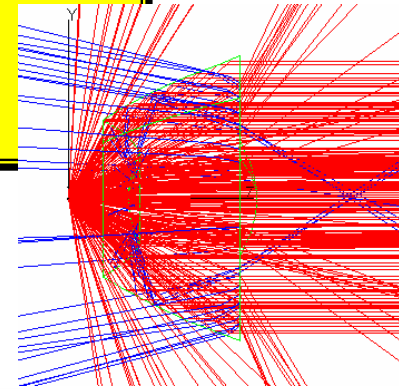

Source size 0.1×0.1 mm² (62.8%)

2×2 mm² (59.8%)

On Caldwell's collection

- Only printed form
 - Not included in Caldwell's LensVIEW
 - **more than 30,000 individual lens designs** from the US patent literature, the Japanese patent literature, as well as *The Zeiss Index of Photographic Lenses*.
 - Download the fully functioning LensVIEW Demo (5.4 MBytes) containing 167 lens design examples from 59 randomly selected patents.

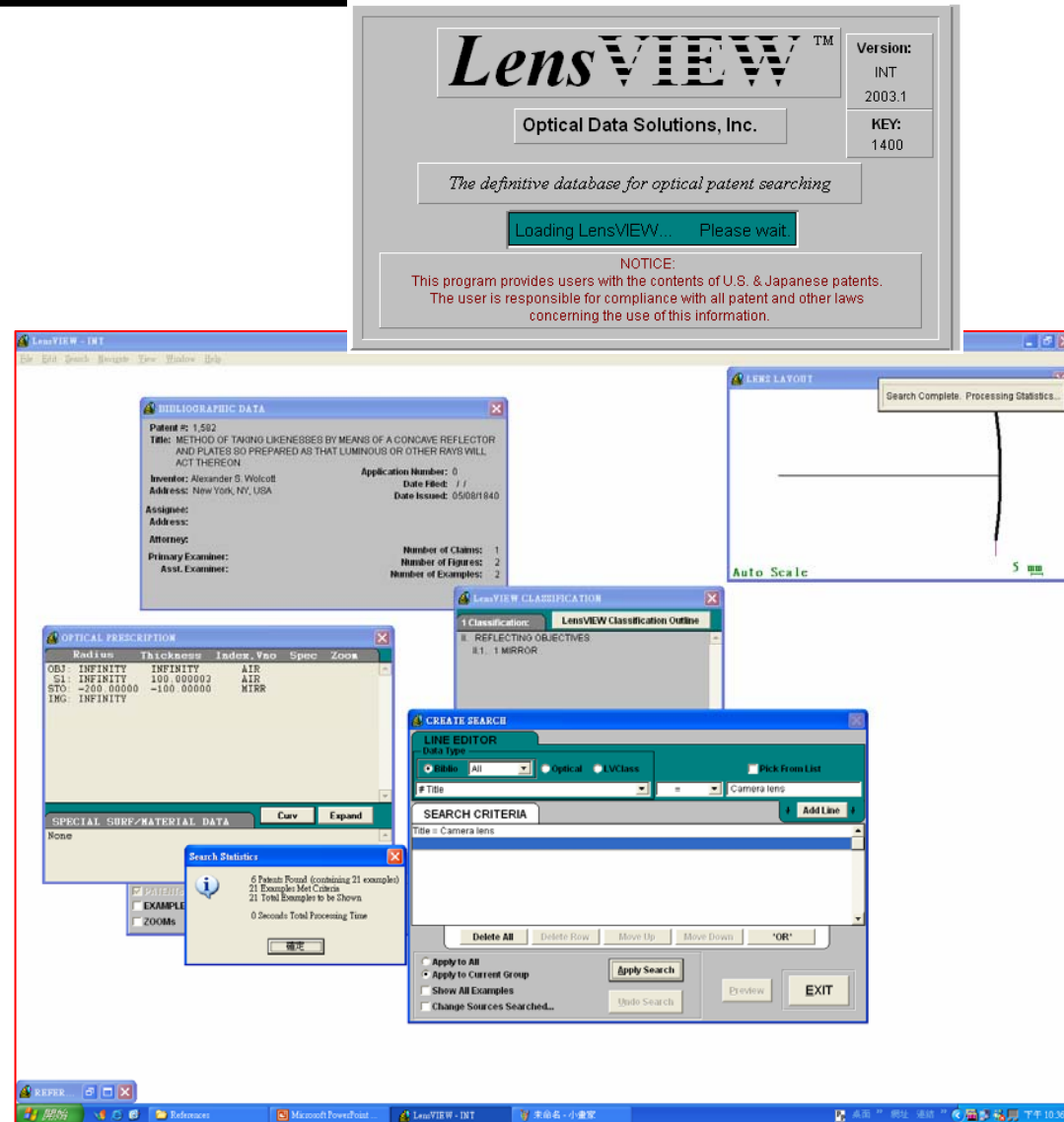

Selected patents

- Zoom lens for digital camera (US 6014268)
 - “Two group small zoom” by S. Yahagi
- High-resolution CCD lens (US 5706141)
 - “photographing lens” by T. Abe
- Zoom enlarging lens (US 5696633)
 - “Varifocal lens” by M. Nakjima
- Wide-angle soft focus photographic lens (US 5822132)
 - “Soft focus lens” by J. Hirakawa
- Fast zoom fisheye lens for electronic cameras (US 5877901)
 - “super wide-angle zoom lens” by T. Enomoto and T. Ito
- An economical triplet for over-head projectors (US 5596455)
 - “Fixed focus triplet projection lens for over-head projectors” by S. K. Eckhardt
- Fast double-Gauss lens (US5920436)
 - “Large-aperture lens for low-illuminance imaging” by Y. Kitahara
- Low-distortion fingerprint detection system (US 5900993)
 - “Lens systems for use in fingerprint detection” by E. Betensky

Zoom lens for digital camera (US 6014268)



US006014268A

United States Patent [19]
Yahagi

[11] **Patent Number:** 6,014,268
[45] **Date of Patent:** Jan. 11, 2000

[54] **TWO-GROUP SMALL ZOOM LENS** 4,266,860 5/1981 Hayashi 359,681
4,540,249 9/1985 Mogami 359,681
[75] **Inventor:** Satoshi Yahagi, Saitama, Japan 5,552,937 9/1996 Ono et al. 359,691
5,781,349 7/1998 Sugawara 359,691
[73] **Assignee:** Fuji Photo Optical Co., Ltd., Omiya, Japan 5,844,724 12/1998 Foo 359,691

[21] **Appl. No.:** 09/024,265

[22] **Filed:** Feb. 17, 1998

[30] **Foreign Application Priority Data**

Apr. 30, 1997 [JP] Japan 9-126508

[51] **Int. Cl.⁷** G02B 15/14

[52] **U.S. Cl.** 359/691; 359/682

[58] **Field of Search** 359/691, 680,
359/681, 682, 676, 683

[56] **References Cited**

U.S. PATENT DOCUMENTS

4,169,660 10/1979 Nakamura 359/681

Primary Examiner—Georgia Epps
Assistant Examiner—Jordan M. Schwartz
Attorney, Agent, or Firm—Arnold International; Bruce Y. Arnold

[57] **ABSTRACT**

An inexpensive, high performance zoom lens includes, as measured from the object side, a negative first lens group and a positive second lens group. The overall length of the zoom lens is reduced by making one of the lens element surfaces of the first lens group G_1 aspherical. A lens element in the second lens group is designed to be a biconvex lens with the same absolute value of radii of curvature, to thereby make the zoom lens inexpensive to produce and assemble.

4 Claims, 6 Drawing Sheets

- **Set aspheric for the second/first surface to correct distortion**
 - This can be traced back to 1960s in design of wide-angle reserved telephoto system
- **Design suitable for SXGA application**
 - MTF for SXGA 0.4@ 160lp/mm
 - SXGA: 1280X1024
 - MTF for VGA 0.5@ 80lp/mm
 - VGA: 640X480

Yahagi's patent

Two modes: (1) wide angle; (2) telecentric mode

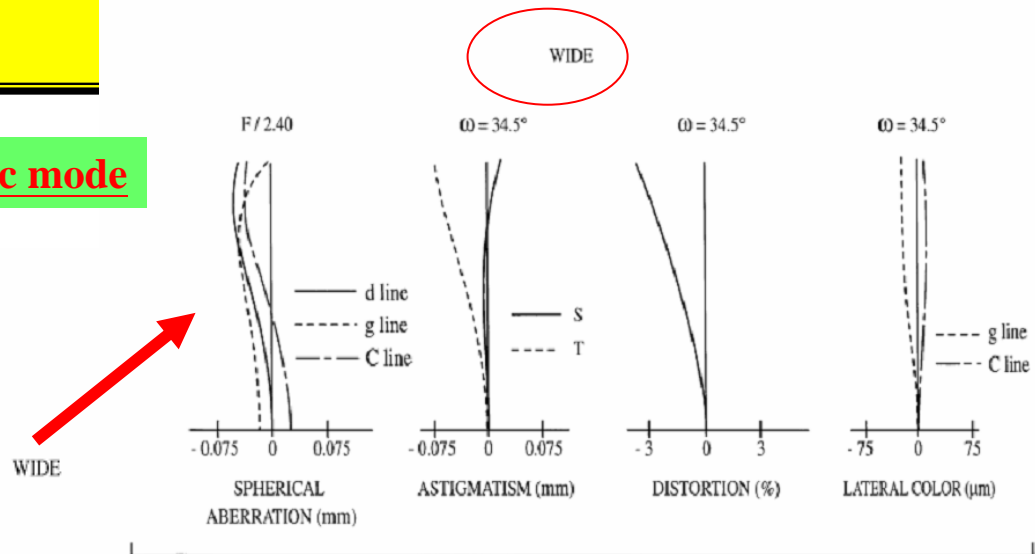
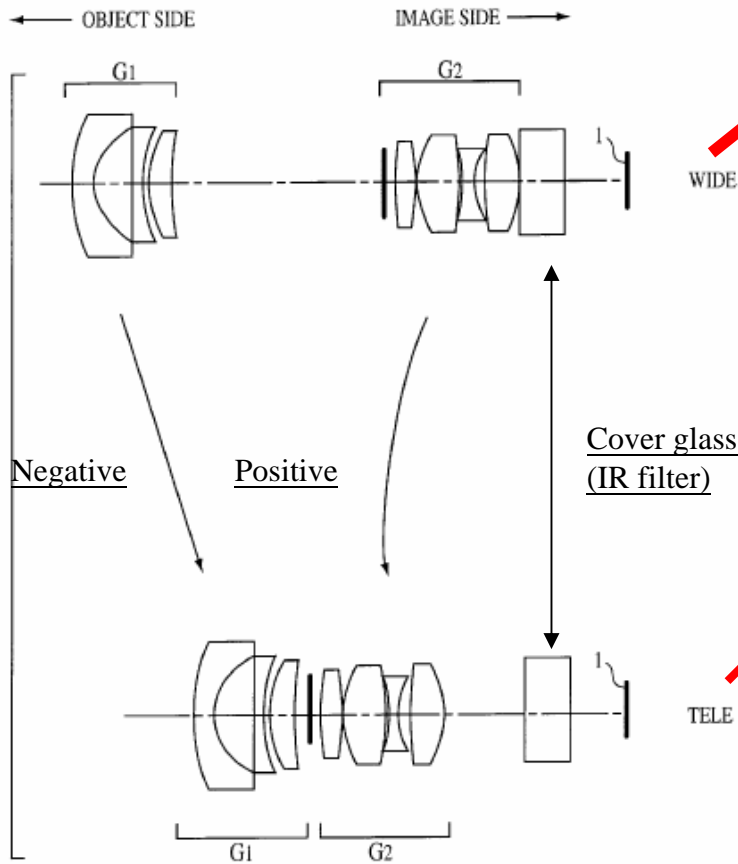

Designs of different f/# were also provided

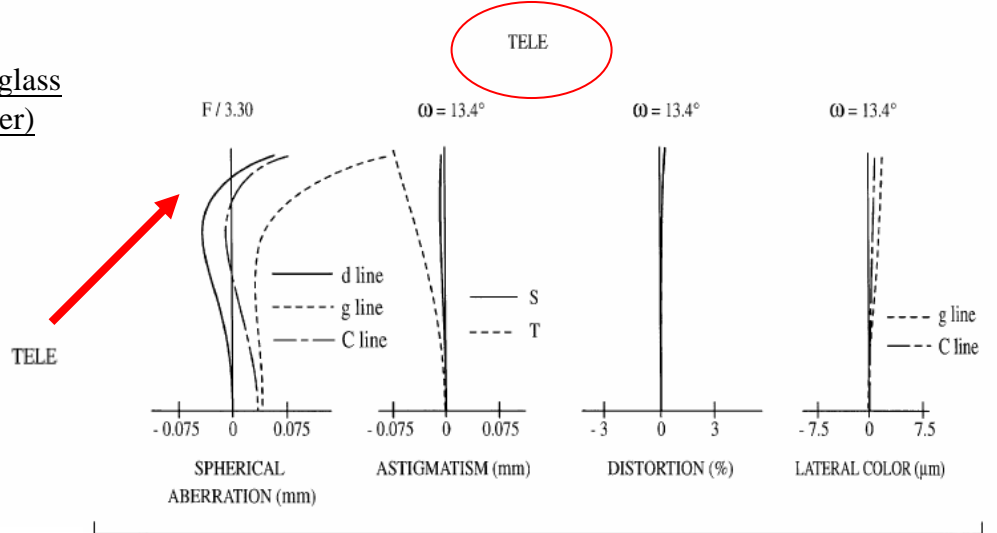

Yahagi's patent/ example 1

TABLE 1

#	R	D	N_d	v_d
1	14.610	1.50	1.68800	55.9
2*	4.081	3.20		
3	65.049	1.00	1.77250	49.6
4	11.071	0.45		
5	8.368	1.96	1.72824	28.3
6	24.483	variable distance 1		
7	∞	0.80		
8	26.502	1.67	1.71300	53.9
9	-26.502	0.10		
10	7.244	3.55	1.80501	39.6
11	-30.617	0.14		
12	-14.141	1.00	1.84665	23.9
13	5.434	0.92		
14	21.449	2.82	1.71300	53.9
15	-8. 145	variable distance 2		
16	∞	3.50	1.51633	64.0
17	∞			

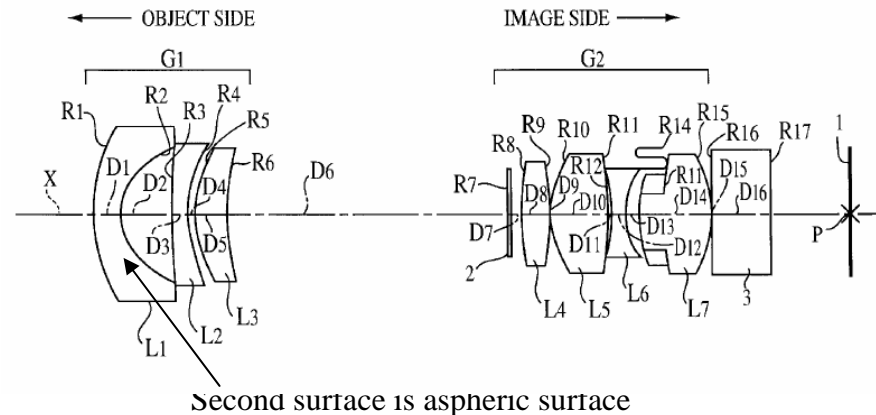

Small-size lens

TABLE 2

#	C	K	A_4	A_6	A_8	A_{10}
2	0.24506	0.56384	8.9390×10^5	-5.0000×10^{-8}	-9.2860×10^{-11}	1.4862×10^{13}
			Maximum wide-angle state	Maximum telephoto state		
Variable distance 1			17.38	1.34		
Variable distance 2			0.0	6.57		
			$f = 3.37-9.44 \text{ mm}$	$F_{No.} = 2.40-3.30$		

You still need some efforts to achieve the desired performance

Yahagi's patent /example 2

TABLE 3

#	R	D	N_d	v_d
1*	21.362	1.70	1.69081	53.0
2	5.150	2.68		
3	50.445	1.00	1.77250	49.6
4	7.742	0.95		
5	8.241	2.07	1.72824	28.3
6	28.793	variable distance 1		
7	∞	0.80		
8	26.502	1.67	1.71300	53.9
9	-26.502	0.10		
10	7.244	3.55	1.80501	39.6
11	-30.617	0.14		
12	-14.141	1.00	1.84665	23.9
13	5.434	0.92		
14	21.449	2.82	1.71300	53.9
15	-8.145	variable distance 2		
16	∞	3.50	1.51633	64.0
17	∞			

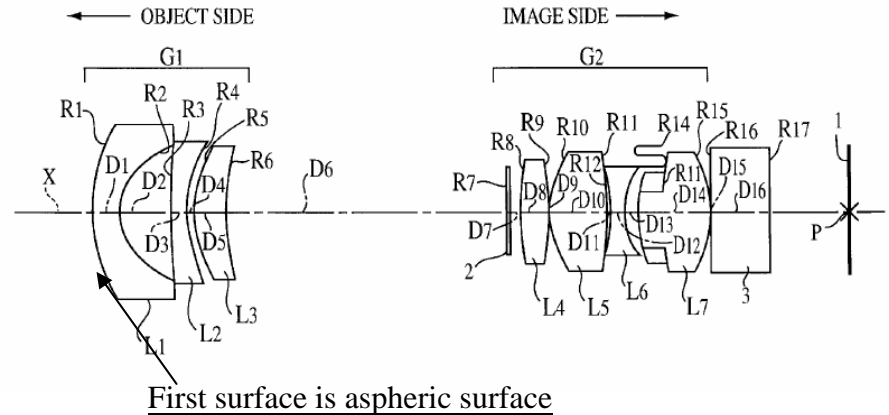

TABLE 4

#	C	K	A_4	A_6	A_8	A_{10}
1	0.04681	4.70244	1.5087×10^{-4}	2.2011×10^{-7}	2.9843×10^{-9}	-5.6184×10^{-12}
			Maximum wide-angle state		Maximum telephoto state	
Variable distance 1			17.08		1.30	
Variable distance 2			0.0		6.68	
			$f = 3.37-9.43$		$F_{No.} = 2.39-3.33$	

High-resolution CCD lens (US5706141)



US005706141A

United States Patent [19]
Abe

[11] **Patent Number:** 5,706,141
[45] **Date of Patent:** Jan. 6, 1998

[54] **PHOTOGRAPHING LENS**

5,280,390 1/1994 Ito .
5,490,014 2/1996 Suzuki 359/745
5,546,232 8/1996 Hirakawa .

[75] **Inventor:** Tetsuya Abe, Hokkaido, Japan

[73] **Assignee:** Asahi Kogaku Kogyo Kabushiki Kaisha, Tokyo, Japan

[21] **Appl. No.:** 745,463

[22] **Filed:** Nov. 12, 1996

[30] **Foreign Application Priority Data**

Primary Examiner—David C. Nelms
Assistant Examiner—John P. Cornely
Attorney, Agent, or Firm—Greenblum & Bernstein P.L.C.

[57] **ABSTRACT**

A photographing lens includes a first lens group, a diaphragm, and a positive second lens group, in this order from the object side. The photographing lens satisfies the following relationships: $|f/f_1| < 0.2$, and $0.7 < h_{1-L}/h_{1-L} < 1.0$. In the above relationships, “f” designates the focal length of the entire photographing lens, “ f_1 ” the focal length of the first lens group, “ h_{1-L} ” the height of the incident point of paraxial rays on axis on the first surface of the first lens group, and “ h_{1-L} ” the height of the incident point of paraxial on-axis rays on the last surface of the first lens group, respectively.

3 Claims, 6 Drawing Sheets

- Lens are compact
 - Diagonal is small, 2.7-5.5 mm
 - Tessar / double Gauss can't be applied because back focal length is too small
 - A kind of reversed telephoto design is preferred
- Lenses are either bi-concave or bi-convex
- Back focal length is 7.7 mm (1.46 f)
- MTF is ~0.5 @ 80lp/mm

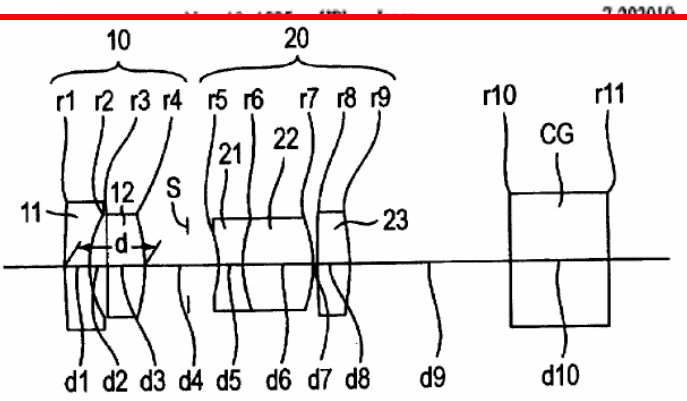

Abe's patent/ Example 1

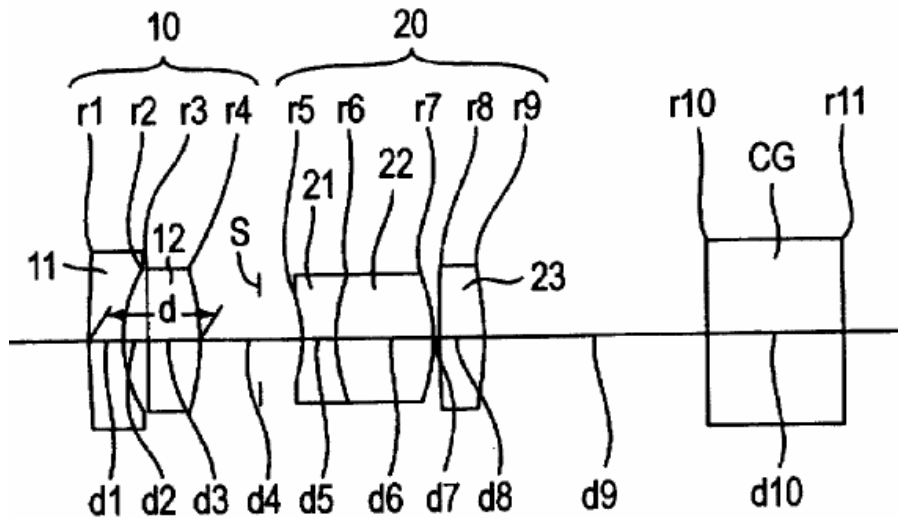

All spherical lenses
Small size

TABLE 1

$F_{NO} = 1:2.8$
 $f = 5.22$
 $W = 24.2$
 $f_B = 7.76$

surface No.	R	D	N_d	v_d
1	28.233	0.80	1.51633	64.1
2	3.300	0.54	—	—
3	24.750	1.30	1.80518	25.4
4	-7.700	1.43	—	—
diaphragm	∞	1.02	—	—
5	-4.080	0.80	1.80518	25.4
6	3.982	2.40	1.67003	47.2
7	-4.000	0.10	—	—
8	25.010	1.10	1.81600	46.6
9	-9.680	5.54	—	—
10	∞	3.32	1.49782	66.8
11	∞	—	—	—

Abe's patent / Example 2

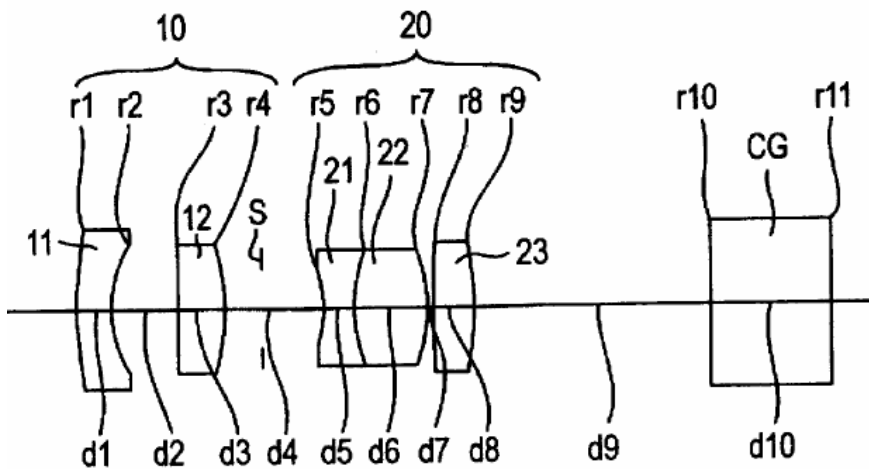

All spherical lenses
Small size

TABLE 2

$F_{NO} = 1:2.8$
 $f = 5.22$
 $W = 24.2$
 $f_B = 8.55$

surface No.	R	D	N_d	v_d
1	12.300	0.80	1.65844	50.9
2	3.120	1.85	—	—
3	47.807	1.30	1.80518	25.4
4	-6.818	1.00	—	—
diaphragm	∞	1.59	—	—
5	-4.357	0.80	1.80518	25.4
6	4.483	2.00	1.63930	44.9
7	-3.894	0.10	—	—
8	23.354	1.10	1.69680	55.5
9	-9.260	6.33	—	—
10	∞	3.32	1.49782	66.8
11	∞	—	—	—

Abe's patent / Example 3

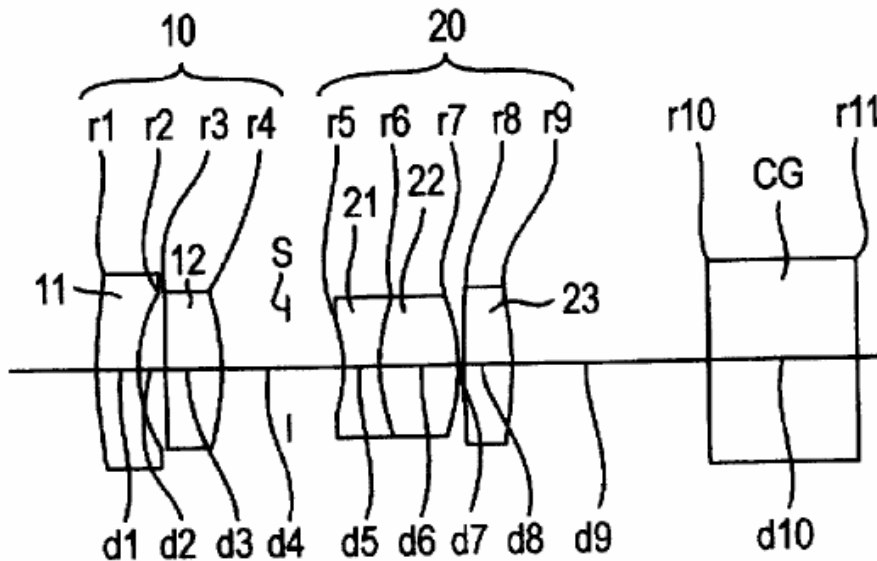

All spherical lenses
Small size

TABLE 3

$F_{NO} = 1:2.8$
 $f = 5.21$
 $W = 24.5$
 $f_B = 6.73$

surface No.	R	D	N_d	v_d
1	7.040	0.80	1.48749	70.2
2	3.177	0.64	—	—
3	30.760	1.30	1.80518	25.4
4	-14.420	1.48	—	—
diaphragm	∞	1.17	—	—
5	-3.519	0.80	1.72825	28.5
6	2.822	1.80	1.68578	44.0
7	-3.752	0.10	—	—
8	11.410	1.10	1.80400	46.6
9	-14.900	4.51	—	—
10	∞	3.32	1.49782	66.8
11	∞	—	—	—

Abe's patent /example 4

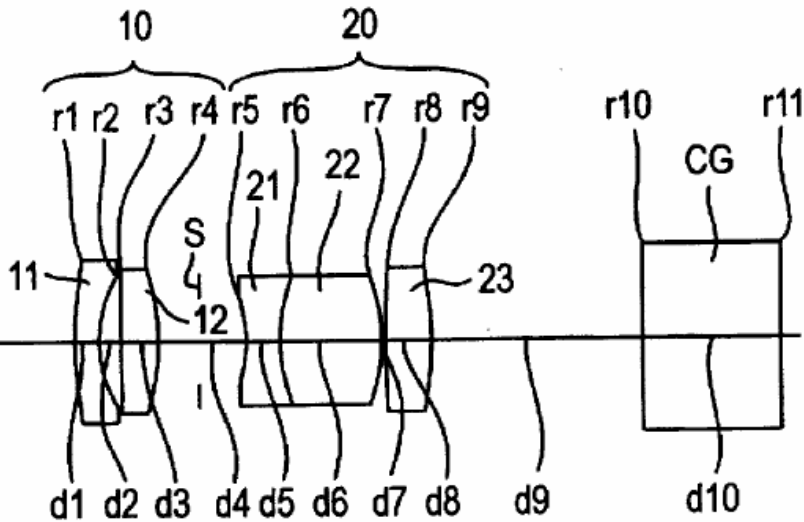

All spherical lenses
Small size

TABLE 4

$F_{NO} = 1:2.8$
 $f = 5.26$
 $W = 24.1$
 $f_B = 7.19$

surface No.	R	D	N_d	v_d
1	18.246	0.60	1.56384	60.7
2	4.000	0.40	—	—
3	14.204	0.90	1.78472	25.7
4	-9.482	1.00	—	—
diaphragm	∞	1.08	—	—
5	-3.025	0.80	1.71736	29.5
6	3.000	2.40	1.62280	57.1
7	-3.643	0.10	—	—
8	16.477	1.10	1.77250	49.6
9	-9.376	4.97	—	—
10	∞	3.32	1.49782	66.8
11	∞	—	—	—

Abe's patent / example 5

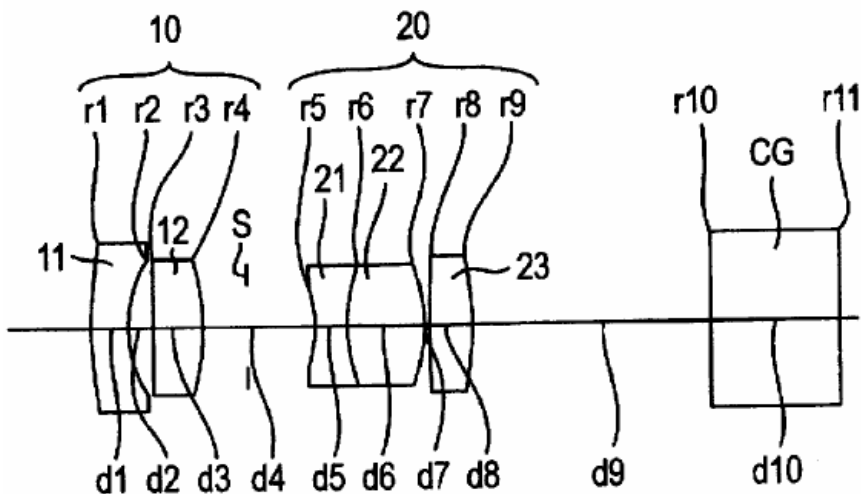

All spherical lenses
Small size

TABLE 5

$F_{NO} = 1:2.8$
 $f = 5.25$
 $W = 24.1$
 $f_B = 8.22$

surface No.	R	D	N_d	v_d
1	10.803	0.80	1.55963	61.2
2	2.900	0.80	—	—
3	-250.203	1.30	1.80518	25.4
4	-7.107	1.00	—	—
diaphragm	∞	1.64	—	—
5	-4.206	0.80	1.74000	28.3
6	4.050	2.00	1.61484	51.2
7	-3.707	0.10	—	—
8	18.742	1.10	1.69680	55.5
9	-9.157	6.00	—	—
10	∞	3.32	1.49782	66.8
11	∞	—	—	—

Abe's patent / Example 6

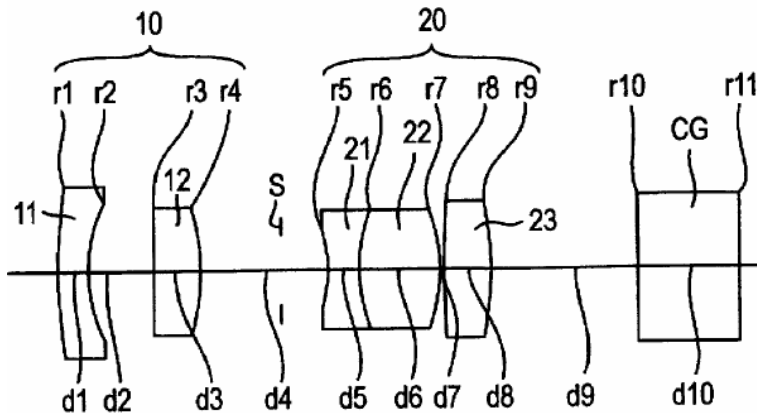

All spherical lenses
Small size

TABLE 6

$F_{NO} = 1:2.8$
 $f = 5.26$
 $W = 24.6$
 $f_B = 7.77$

surface No.	R	D	N_d	v_d
1	13.650	0.80	1.69680	55.5
2	4.284	2.12	—	—
3	34.227	1.40	1.80518	25.4
4	-9.600	2.45	—	—
diaphragm	∞	1.44	—	—
5	-4.626	0.90	1.84666	23.8
6	4.626	2.45	1.72000	42.0
7	-4.626	0.10	—	—
8	15.243	1.47	1.83481	42.7
9	-15.243	4.36	—	—
10	∞	3.12	1.49782	66.8
11	∞	—	—	—

Results of Search in 1998-2003 db for:

REF/5,706,141: 5 patents.

Hits 1 through 5 out of 5

Jump To

Refine Search

PAT. NO. Title

- 1 [6,236,521](#) Objective lens and image pickup device using the same
- 2 [6,222,685](#) Imaging lens
- 3 [6,028,711](#) Reading lens
- 4 [5,999,337](#) Lens system for electronic photography
- 5 [5,940,214](#) Optical arrangement with diffractive optical element

Zoom enlarging lens (US5696633)



US005696633A

United States Patent [19]
Nakajima

[11] **Patent Number:** 5,696,633

[45] **Date of Patent:** Dec. 9, 1997

[54] **VARIFOCAL LENS**

[75] **Inventor:** Masaya Nakajima, Yokohama, Japan

[73] **Assignee:** Nikon Corporation, Tokyo, Japan

[21] **Appl. No.:** 608,430

[22] **Filed:** Feb. 28, 1996

[30] **Foreign Application Priority Data**

Mar. 2, 1995 [JP] Japan 7-068627

[51] **Int. Cl.⁶** G02B 15/14

[52] **U.S. Cl.** 359/691; 359/689

[58] **Field of Search** 359/691, 689

[56] **References Cited**

U.S. PATENT DOCUMENTS

4,934,794	6/1990	Ueda	359/689
4,938,572	7/1990	Iwasaki	359/689
5,073,015	12/1991	Ueda	359/689

FOREIGN PATENT DOCUMENTS

SHO			
61-59306	3/1986	Japan	.
SHO			
61-129613	6/1986	Japan	.
3-196110	8/1991	Japan	.

Primary Examiner—Scott J. Sugarman
Attorney, Agent, or Firm—Klarquist Sparkman Campbell
Leigh & Whinston, LLP

[57] **ABSTRACT**

A varifocal lens is disclosed that includes, in order front to rear, a first lens group having an overall negative focal length and a second lens group having an overall positive focal length. The first and second lens groups are axially separated by a space that changes as the focal length of the varifocal lens is changed. The first lens group comprises, in order from front to rear, a biconcave lens element and a positive lens element. The second lens group comprises, in order from front to rear, a front subgroup and a rear subgroup. The front subgroup comprises, in order from front to rear, a first positive lens element, a first cemented lens, a second cemented lens having positive refractive power, and a second positive lens element. The rear subgroup comprises, in order from front to rear, a negative lens element, a positive lens element, and a negative meniscus lens element having a convex face oriented rearwardly. The varifocal lens fulfills the conditions:

$$0.8 < f_1/f_2 < 1.7$$

$$0.5 < D/f_2 < 1.2$$

$$1.4 < f_1/f_b < 2.5$$

wherein, f_1 is the focal length of the first lens group, f_2 is the focal length of the second lens group, f_a is the focal length of the front subgroup, f_b is the focal length of the rear subgroup, and D is the distance between the rear principal point of the front subgroup and the front principal point of the rear subgroup. The varifocal lens is especially suitable for use in photographic enlargers.

19 Claims, 12 Drawing Sheets

Total conjugate distance is constant
(a normal requirement)

Allow for making small enlargement of negative ranging up to 56X41.5 mm (6X4.5 cm)

Minimizes variations of both object distance and back focal length with respect to magnification by appropriately varying the telephoto ratio.

Nearly diffraction-limited performance

Nakajima's patent / Example 1

TABLE 1

Surface	Curvature Radius (mm)	Interfacial Distance (mm)	Abbe's Number	Refractive Index
1	-178.3555	2.3100	43.35	1.845033
2	38.7485	2.1700		
3	40.6244	3.0100	32.17	1.677648
4	-1411.4710	d4		
5	55.5926	2.6600	67.87	1.595274
6	-243.2109	0.1400		
7	28.8336	5.4600	65.42	1.605201
8	-50.0528	7.9800	49.45	1.776511
9	31.8972	9.8000		
10	107.5200	2.5900	35.19	1.754548
11	30.4352	4.9000	69.98	1.520370
12	-47.0860	1.0500		
13	24.8572	4.2000	64.10	1.518723
14	27.5167	19.2500		
15	-20.7264	2.1000	64.10	1.518723
16	-113.6105	2.2400		
17	2758.6812	6.3000	36.98	1.616859
18	-29.8412	2.1000	65.42	1.605201
19	-224.6821	Bf		

Variables during magnification change:

Variable	Low Mag.	Med. Mag.	High Mag.
β	-0.76923	-0.50000	-0.33333
d0	339.91002 mm	378.28035 mm	400.27264 mm
d4	0.57917 mm	5.20468 mm	14.38414 mm
Bf	137.79281 mm	94.79699 mm	63.62523 mm

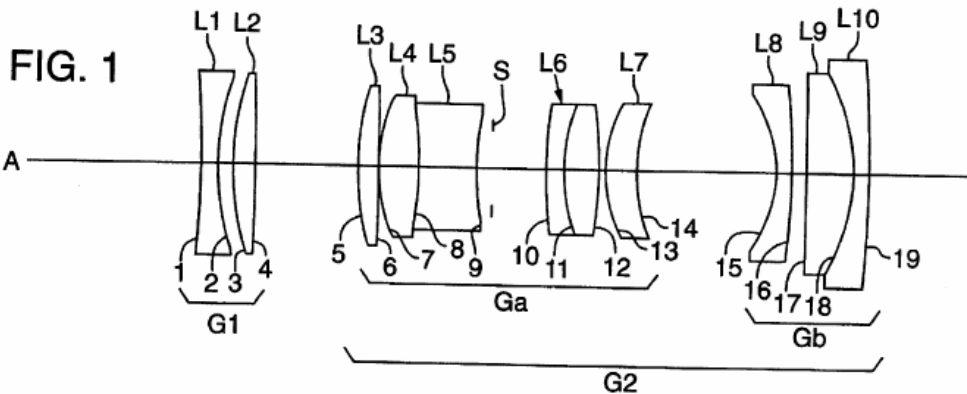

All spherical lenses

High magnification short effective focal length

Telephoto ratio is still large (from 1-1.31)

Good for further processing

β is the magnification at the film surface when light rays are traced from the front side.

Nakajima's patent / Example 2

TABLE 2

Surface No.	Curvature Radius (mm)	Interfacial Distance (mm)	Abbe's Number	Refractive Index
Focal length (f):		94.24 to 120.93 mm		
F number:		7.9 to 9.3		
Overall distance:		556.54 mm		
Image diameter:		69 mm		
20	-178.3555	2.3100	43.35	1.845033
21	38.7485	2.1700		
22	40.6244	3.0100	32.17	1.677648
23	-1411.4710	d23		
24	55.1965	2.6600	67.87	1.595274
25	-240.3532	0.1400		
26	28.7389	5.4600	65.42	1.605201
27	-49.5750	7.9800	49.45	1.776511
28	31.9368	9.8000		
29	106.9340	2.5900	35.19	1.754548
30	29.1736	4.9000	69.98	1.520370
31	-46.8480	1.0500		
32	24.8144	4.2000	64.10	1.518723
33	27.8494	19.2500		
34	-21.0349	2.1000	64.14	1.518723
35	-80.3846	0.7000		
36	-3851.8283	6.3000	36.27	1.616859
37	-26.4626	1.4000		
38	-26.2264	2.1000	65.42	1.605201
39	-224.6834	Bf		

Variables during magnification change:

Variable	Low Mag.	Med. Mag.	High Mag.
β	-0.76923	-0.50000	-0.33333
d0	339.70964 mm	377.26401 mm	398.74894 mm
d23	0.79643 mm	5.24765 mm	14.07497 mm
Bf	133.96043 mm	91.95484 mm	61.64259 mm

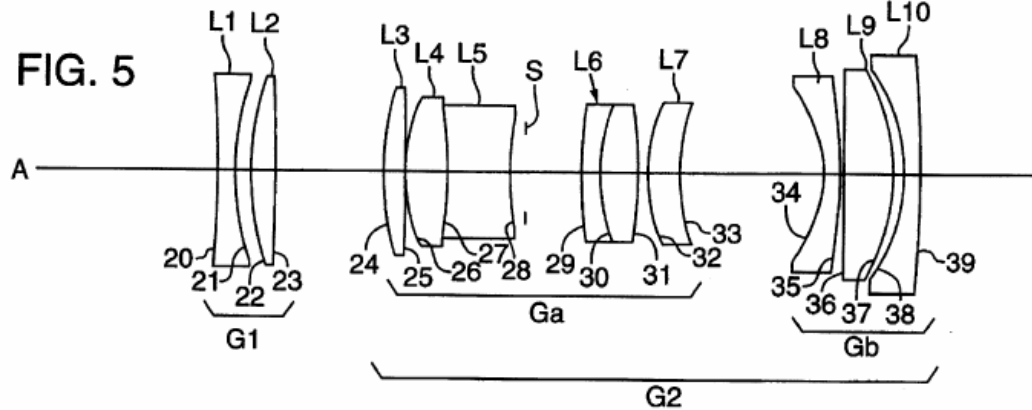

All spherical lenses

Nakajima's patent / Example 3

TABLE 3

Surface No.	Curvature Radius (mm)	Interfacial Distance (mm)	Abbe's Number	Refractive Index
Focal length (f):		96.96–123.38 mm		
F number:		8.0–9.4		
Overall distance:		556.55 mm		
Image diameter:		69 mm		
40	-178.3555	2.3100	43.35	1.845033
41	38.7485	2.1700		
42	40.6244	3.0100	32.17	1.677648
43	-1411.4710	d43		
44	50.8259	2.6600	67.87	1.595274
45	522.9922	0.1400		
46	26.2875	5.4600	65.42	1.605201
47	-267.6564	7.9800	49.45	1.776511
48	27.4925	9.8000		
49	35.8992	2.5900	69.98	1.520370
50	-23.0833	4.9000	35.19	1.754548
51	-80.1635	1.0500		
52	27.3770	4.2000	64.10	1.518723
53	24.1454	19.2500		
54	-18.5218	2.1000	61.09	1.591430
55	-39.8507	2.2400		
56	-251.4136	6.3000	27.61	1.761660
57	-49.2703	2.1000	67.87	1.595274
58	-244.6824	Bf		

Variables during magnification change:

Variable	Low Mag.	Med. Mag.	High Mag.
β	-0.76923	-0.50000	-0.33333
d0	343.69722 mm	381.44790 mm	403.06766 mm
d4	0.79924 mm	5.27091 mm	14.13690 mm
Bf	133.79470 mm	94.90283 mm	65.18426 mm

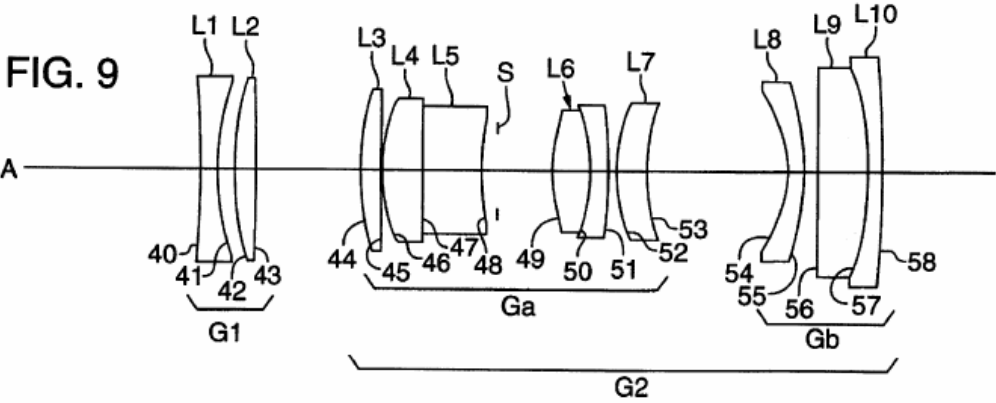

All spherical lenses

Results of Search in 1790 to present db for:
 REF/5696633: 2 patents.
 Hits 1 through 2 out of 2

Only to 2003

Jump To

Refine Search

PAT. NO. Title

1 6,142,630 Variable focus lens system such as for examination or treatment of transparent or semi-transparent materials such as ocular tissue

2 6,075,658 Imaging lens

Wide-angle soft focus photographic lens (US 5822132)



US005822132A

United States Patent [19]
Hirakawa

[11] **Patent Number:** **5,822,132**

[45] **Date of Patent:** **Oct. 13, 1998**

[54] **SOFT FOCUS LENS**

[75] **Inventor:** Jun Hirakawa, Tokyo, Japan

[73] **Assignee:** Asahi Kogaku Kabushiki Kaisha, Tokyo, Japan

[21] **Appl. No.:** 772,251

[22] **Filed:** Dec. 23, 1996

[30] **Foreign Application Priority Data**

Dec. 25, 1995 [JP] Japan 7-351074

[51] **Int. Cl.⁶** **G02B 15/14**

[52] **U.S. Cl.** **359/691; 359/692; 359/698; 359/707; 359/795**

[58] **Field of Search** **359/691, 692, 359/698, 707, 795**

5,233,474 8/1993 Hirakawa .
5,267,086 11/1993 Hirano .

Primary Examiner—Frank G. Font
Assistant Examiner—Reginald A. Ratliff
Attorney, Agent, or Firm—Greenblum & Bernstein, P.L.C.

[57] **ABSTRACT**

A soft focus lens which is designed as a retrofocus type lens, comprises a front lens group having a negative power, a rear lens group having positive power, and a diaphragm located within the rear lens group. The front and rear lens groups are arranged in this order from an object side. In particular, the soft focus lens satisfies the following conditions;

$$SAU/f < -0.10 \quad (1)$$

$$f/FF < 0.5 \quad (2)$$

where

SAU is spherical aberration at full open aperture, f is focal length of the whole lens system, and FF is focal length of the front lens group.

5 Claims, 12 Drawing Sheets

[56] **References Cited**

U.S. PATENT DOCUMENTS

4,203,653 5/1980 Mori 359/753
4,830,473 5/1989 Kudo 359/717
4,948,236 8/1990 Hirano .

Intended for landscape photography

1. **Having a large amount of special aberration**
2. **Usually available for moderately long focal length (portraiture)**

Unusual design

(similar 1980 Canon's patent, US patent 4781446)
A fairly conventional-looking reverse telephoto lens

1. **Covering a full-field angle of 68.4 degrees**
2. **f/3.6**

Hirakawa's patent / example 1

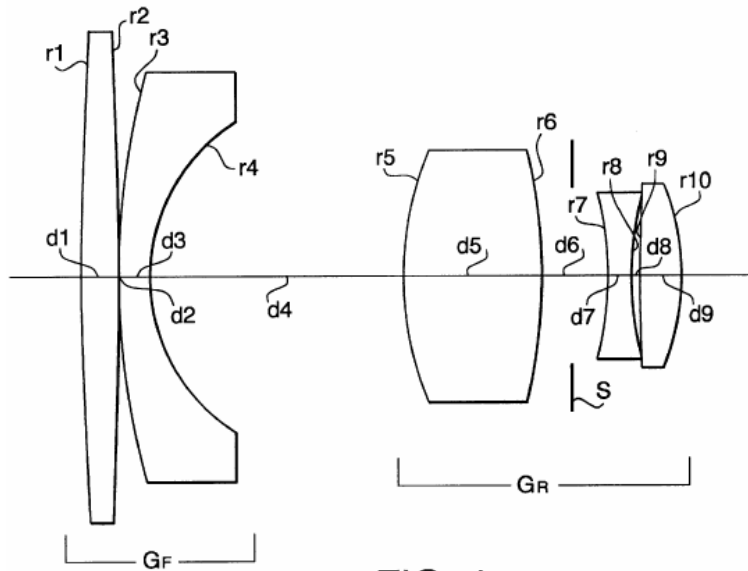

FIG. 1

TABLE 1

$f = 100.00$	$f_B = 127.25$	$f_F = -115.765$		
$FNo. = 1:2.9$	$\omega = 37.9^\circ$	$SAU = -22.0$		
Surface number	r	d	n	v
1	1351.000	10.43	1.58913	61.2
2	-1509.940	0.35		
3	225.400	8.34	1.62041	60.3
4	49.740	69.55		
5	84.270	38.23	1.77250	49.6
6	-169.980	18.08		
7	-84.600	6.95	1.78470	26.2
8	124.890	2.29		
9	686.550	11.14	1.77250	49.6
10	-64.470			

Hirakawa's patent / example 2

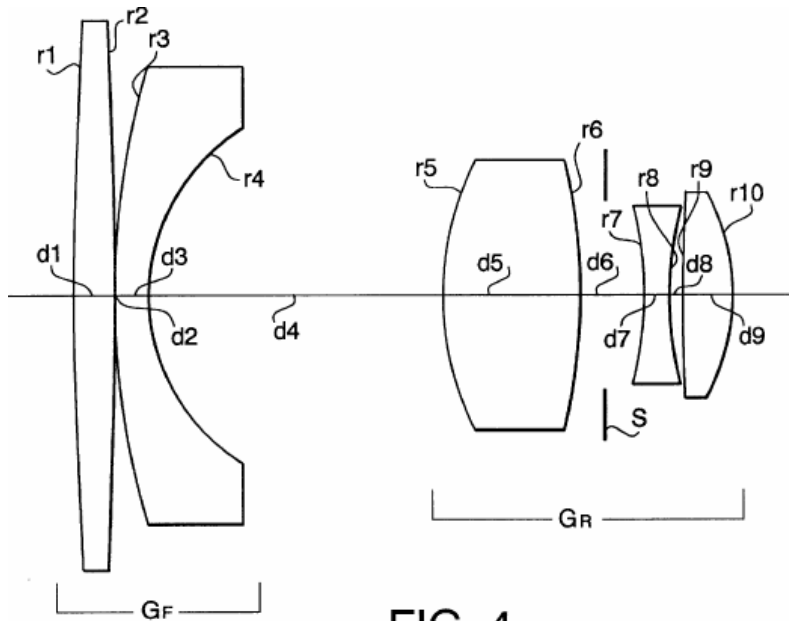

FIG. 4

TABLE 2

Surface number	r	d	n	v
1	1293.910	10.43	1.69680	55.5
2	-1752.260	0.35		
3	231.480	8.34	1.58913	61.2
4	49.860	75.68		
5	82.910	35.13	1.74230	49.3
6	-157.810	17.37		
7	-85.220	6.95	1.76180	27.1
8	121.140	3.17		
9	658.350	12.00	1.69680	55.5
10	-61.860			

$f = 100.04$
 $FNo. = 1:2.9$
 $fB = 128.10$
 $\omega = 37.9^\circ$
 $fF = -123.660$
 $SAU = -24.5$

Hirakawa's patent / example 3

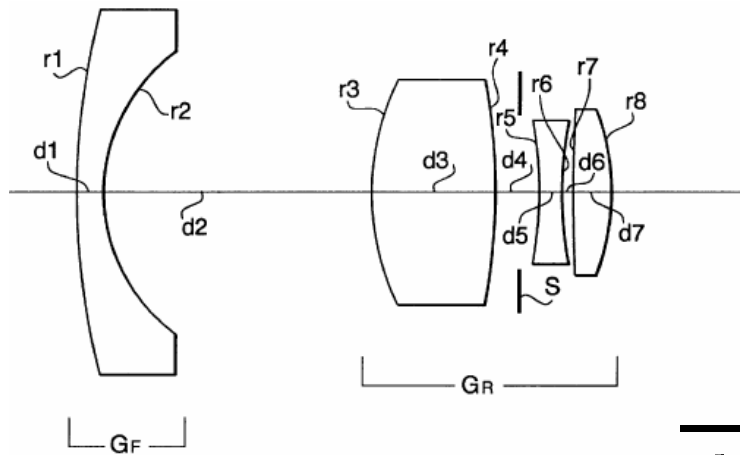

FIG. 7

TABLE 3

Surface number	r	d	n	v
1	194.200	7.00	1.58913	61.2
2	46.142	70.00		
3	69.557	32.00	1.74230	49.3
4	-132.395	12.00		
5	-71.495	5.83	1.76180	27.1
6	101.630	2.66		
7	552.323	10.00	1.69680	55.5
8	-60.996			

f = 100.00
FNo. = 1:3.6

fB = 134.97
 $\omega = 34.2^\circ$

fF = -104.565
SAU = -18.9

Hirakawa's patent / example 4

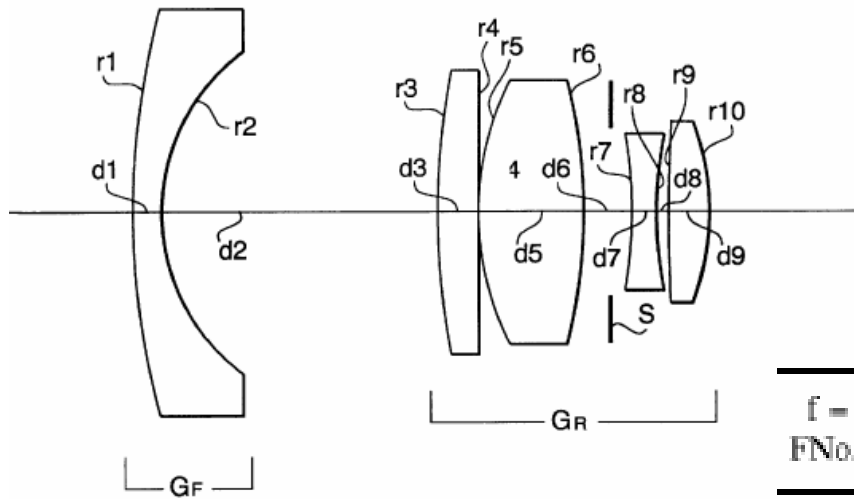

FIG. 10

TABLE 4

$f = 100.00$	$fB = 136.71$	$fF = -104.570$		
$FNo. = 1:3.6$	$\omega = 34.0^\circ$	$SAU = -12.6$		
Surface number	r	d	n	v
1	194.200	7.00	1.61800	63.4
2	47.821	66.00		
3	200.000	10.00	1.48749	70.2
4	∞	0.00		
5	70.000	25.00	1.60311	60.7
6	-115.347	12.00		
7	-71.495	5.83	1.72047	34.7
8	85.261	2.66		
9	552.323	10.00	1.69680	55.5
10	-59.099			

Results of Search in 1790 to present db for:

REF/5822132: 3 patents.

Hits 1 through 3 out of 3

Only to 2003

Jump To

Refine Search

PAT. NO. Title

1 [6,552,857](#) [Soft-focus lens system](#)

2 [6,212,017](#) [Soft focus lens systems](#)

3 [5,991,093](#) [Soft-focus zoom lens system](#)

Fast zoom fisheye lens for electronic cameras (US 5877901)



US005877901A

United States Patent [19]
Enomoto et al.

[11] **Patent Number:** **5,877,901**
[45] **Date of Patent:** **Mar. 2, 1999**

[54] **SUPER WIDE-ANGLE ZOOM LENS**
[75] **Inventors:** Takashi Enomoto; Takayuki Ito, both of Tokyo, Japan
[73] **Assignee:** Asahi Kogaku Kogyo Kabushiki Kaisha, Tokyo, Japan

4,844,599	7/1989	Ito .	
4,934,797	6/1990	Hirakawa .	
5,329,401	7/1994	Sato	359/689
5,371,631	12/1994	Takada .	
5,434,710	7/1995	Zozawa	359/689
5,631,775	5/1997	Shibata	359/689
5,724,193	3/1998	Hirakawa	359/691

[21] **Appl. No.:** 761,789
[22] **Filed:** Dec. 6, 1996
[30] **Foreign Application Priority Data**
Dec. 12, 1995 [JP] Japan 7-323392
[51] **Int. Cl.^o** **G02B 15/14**
[52] **U.S. Cl.** **359/691; 359/681; 359/682; 359/683; 359/689; 359/725; 359/740**
[58] **Field of Search** 359/681, 682, 359/691, 740, 689, 683, 664, 725

FOREIGN PATENT DOCUMENTS

0563615	10/1993	European Pat. Off. .
0620467	10/1994	European Pat. Off. .
1523492	9/1978	United Kingdom .
1576189	10/1980	United Kingdom .

OTHER PUBLICATIONS

"Handbook of Optics: vol. 1 (Sec. Ed.), "Michael Bass (Editor in Chief), McGraw-Hill, Inc., New York, NY, pp. 1.80-1.83, 1995.

"Optics: Second Edition, "Eugene Hecht, Addison-Wesley Publishing Company, Reading, Massachusetts, pp. 198-202, 1987.

United Kingdom Search Report.

Primary Examiner—Georgia Epps

Assistant Examiner—Evelyn A. Lester

Attorney, Agent, or Firm—Greenblum & Bernstein, P.L.C.

[57] **ABSTRACT**

A super wide-angle zoom lens includes at least a negative first lens group and a positive second lens group, in this order from an object side. A zooming operation is carried out by relatively moving the lens groups. When a photographing area is defined by a rectangular area, a boundary of a circular image forming area formed by the zoom lens is at least partially disposed in the rectangular photographing area at the shortest focal length of the zoom lens.

14 Claims, 18 Drawing Sheets

An unusual zoom fisheye design

- 1. Circular fisheye at the short focal length position**
- 2. Diagonal fisheye at the local focal length position**

The field angle remains nearly constant during zooming so that the image circle changes size

Intended for a 1/3" CCD having a diagonal of 6mm

Telecentric throughout the zoom range

NPN design (P: variator)

F/#~1.4

Results of Search in 1790 to present db for:

REF/5877901: 2 patents.

Hits 1 through 2 out of 2

Jump To Only to 2003

Refine Search

PAT. NO.	Title	
1 6,327,098	Wide-angle zoom lens system	359/681
2 6,246,529	Wide-angle zoom lens system	359/681

Enomoto-Ito patent / example 1

FIG. 1

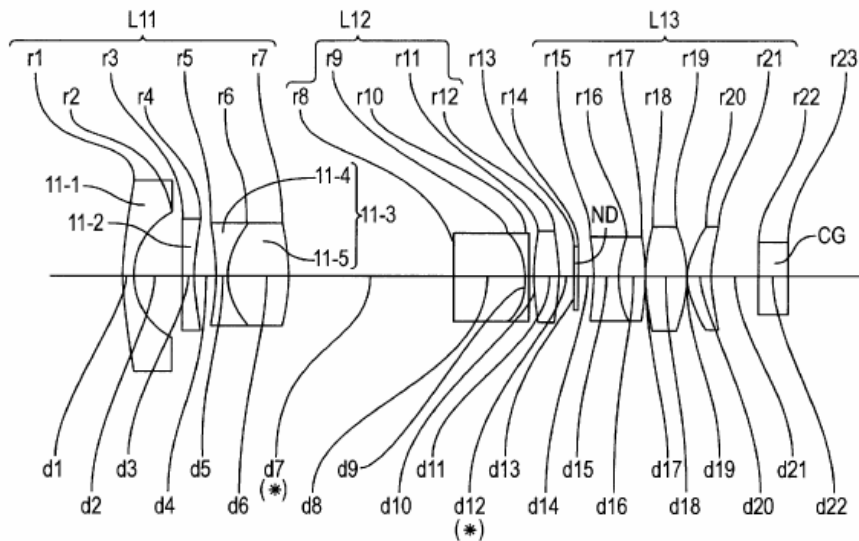

TABLE 1

$f_{B-D21} + D_{22}/N_{22} = 7.70$ (reduced distance)				
Surface No.	R	D	Nd	v_d
1	72.478	1.00	1.77250	49.6
2	7.668	5.63	—	—
3	-137.710	1.26	1.60000	60.7
4	18.664	2.47	—	—
5	-20.127	1.33	1.79348	50.6
6	8.000	6.78	1.75440	27.0
7	-27.233	19.13 - 8.94 - 4.19	—	—
8	-53.602	8.00	1.70000	37.1
9	-7.267	1.03	1.85000	25.2
10	-18.891	0.10	—	—
11	33.189	2.73	1.77250	49.6
12	-27.409	1.64 - 5.09 - 8.20	—	—
13	∞	0.50	1.51633	64.1
14	∞	1.70	—	—
15	-14.541	2.90	1.85000	31.2
16	11.097	3.30	1.51032	60.5
17	-22.765	0.10	—	—
18	26.979	4.59	1.69680	55.5
19	-15.548	0.26	—	—
20	10.011	2.50	1.77250	49.6
21	17.679	5.36	—	—
22	∞	3.50	1.49782	66.8
23	∞	—	—	—

In this embodiment, the picture area is a 1/3" CCD (major side is 4.8 mm; minor side is approximately 3.6 mm; diagonal is about 6.0 mm). The heights Ya and Yb of the picture plane in the directions of the minor side and the major side are as follows, namely, minor side/2=1.8 mm and major side/2=2.4 mm.

(Embodiment 1)			
F	1.61	2.40	3.11
F_{No}	1.4	1.4	1.5
W	90.0°	90.0°	79.4°
Y	1.88	2.82	3.50
Wa(Ya = 1.8)	80.0°	45.8°	34.3°
Wb(Yb = 2.4)	—	65.8°	47.2°
Wc(Yc = 3.0)	—	—	62.3°

Enomoto-Ito patent / example 2

FIG. 5

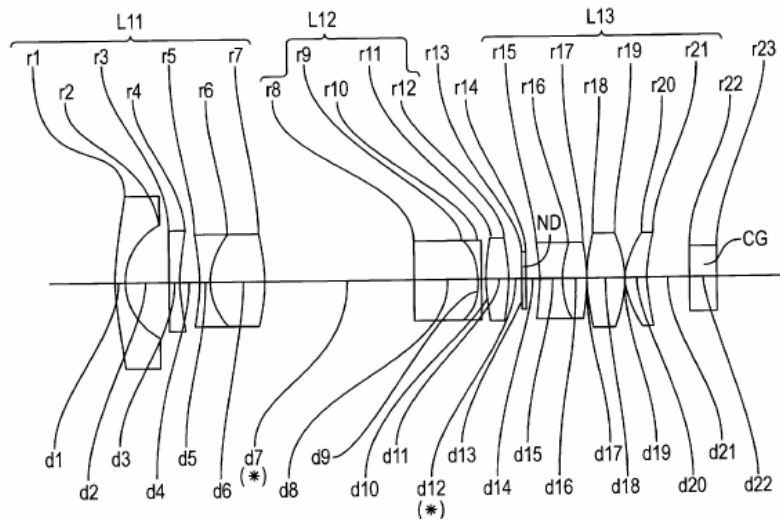

(Embodiment 2)

F	1.65	2.40	3.11
F_{NO}	1.4	1.4	1.4
W	90.0°	90.0°	86.6°
Y	1.87	2.75	3.50
Wa(Ya = 1.8)	80.0°	46.3°	34.5°
Wb(Yb = 2.4)	—	67.5°	47.8°
Wc(Yc = 3.0)	—	—	63.9°

TABLE 2

$$f_{B-D21} + D_{22}/N_{22} = 7.92 \text{ (reduced distance)}$$

Surface No.	R	D	N_d	v_d
1	75.664	1.00	1.77250	49.6
2	8.053	5.71	—	—
3	-312.625	1.73	1.60311	60.7
4	28.045	2.91	—	—
5	-15.775	1.93	1.80400	46.6
6	8.704	7.06	1.72151	29.2
7	-21.013	18.97 - 8.68 - 3.54	—	—
8	-28.537	7.60	1.70154	41.2
9	-10.346	1.20	1.84666	23.8
10	-17.703	0.10	—	—
11	23.358	2.51	1.77250	49.6
12	-100.531	1.62 - 5.50 - 9.16	—	—
13	∞	0.50	1.51633	64.1
14	∞	1.70	—	—
15	-16.417	2.70	1.84666	23.8
16	9.452	3.80	1.64769	33.8
17	-42.359	0.10	—	—
18	27.924	4.72	1.69680	55.5
19	-18.319	0.10	—	—
20	11.093	3.01	1.77250	49.6
21	27.640	5.58	—	—
22	∞	3.50	1.49782	66.8
23	∞	—	—	—

Enomoto-Ito patent / example 3

FIG. 9

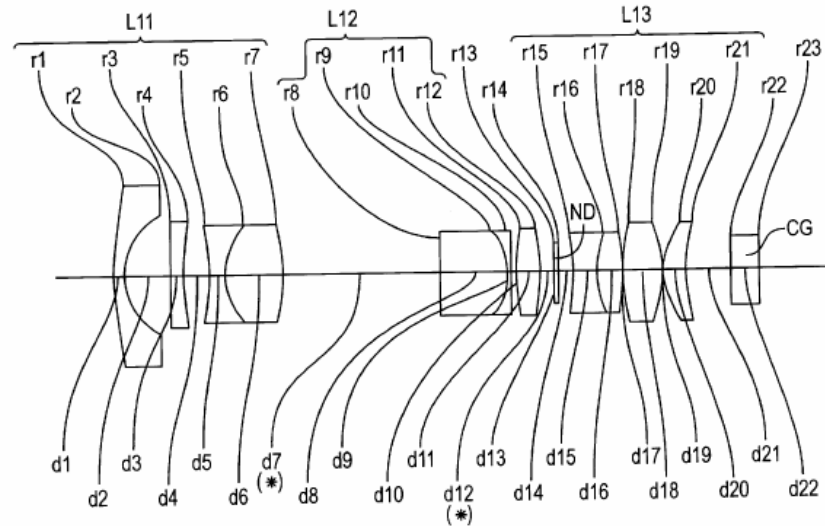

(Embodiment 3)

F	1.60	2.40	3.30
F _{NO}	1.4	1.4	1.4
W	90.0°	90.0°	75.2°
Y	1.80	2.71	3.50
Wa(Ya = 1.8)	90.0°	46.5°	62.4°
Wb(Yb = 2.4)	—	68.4°	44.8°
Wc(Yc = 3.0)	—	—	59.1°

TABLE 3

$$f_B = D_{21} + D_{22}/N_{22} = 8.08 \text{ (reduced distance)}$$

Surface No.	R	D	N _d	v _d
1	85.212	1.00	1.77250	49.6
2	8.102	5.71	—	—
3	-172.558	1.73	1.60311	60.7
4	32.182	2.91	—	—
5	-15.229	1.93	1.80400	46.6
6	8.356	7.06	1.74077	27.8
7	-21.591	20.34 - 8.97 - 2.72	—	—
8	-28.110	7.60	1.70154	41.2
9	-9.615	1.21	1.84666	23.8
10	-17.296	0.10	—	—
11	23.921	2.51	1.77250	49.6
12	-92.900	1.46 - 5.52 - 10.13	—	—
13	∞	0.50	1.51633	64.1
14	∞	2.00	—	—
15	-15.249	2.70	1.84666	23.8
16	9.847	3.80	1.64769	33.8
17	-39.081	0.10	—	—
18	27.821	4.72	1.69680	55.5
19	-19.160	0.10	—	—
20	11.901	3.01	1.77250	49.6
21	40.546	5.74	—	—
22	∞	3.50	1.49782	66.8
23	∞	—	—	—

Enomoto-Ito patent / example 4

FIG. 13

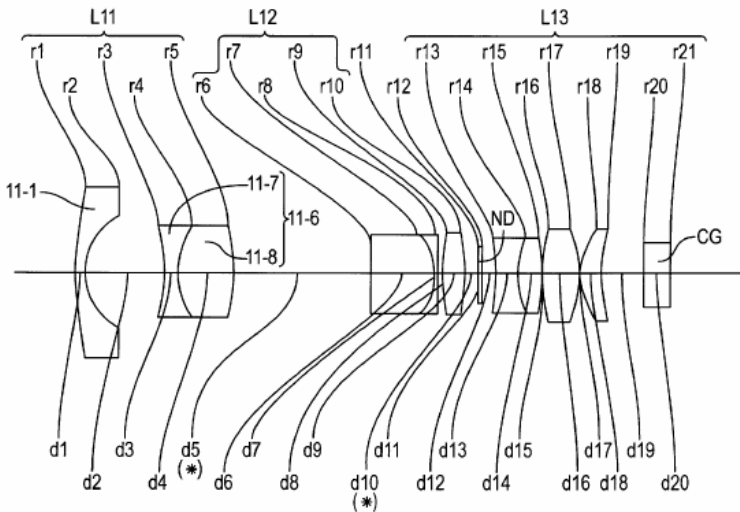

(Embodiment 4)

F	1.92	2.44	3.11
F_{NO}	1.5	1.5	1.4
W	90.0°	90.0°	89.0°
Y	1.98	2.52	3.20
$W_a(Y_a = 1.8)$	69.0°	47.7°	35.5°
$W_b(Y_b = 2.4)$	—	76.0°	50.8°
$W_c(Y_c = 3.0)$	—	—	73.1°

TABLE 4

$$E_B = D_{19} + D_{20}/N_{20} = 7.70 \text{ (reduced distance)}$$

Surface No.	R	D	N_d	v_d
1	98.123	1.00	1.77250	49.6
2	8.995	10.35	—	—
3	-12.239	1.93	1.80400	46.6
4	9.073	7.06	1.74077	27.8
5	-22.851	18.97 - 11.94 - 6.34	—	—
6	-34.240	7.60	1.70154	41.2
7	-9.969	1.21	1.84666	23.8
8	-17.364	0.10	—	—
9	21.921	2.51	1.77250	49.6
10	-374.823	1.90 - 4.22 - 7.22	—	—
11	∞	0.50	1.51633	64.1
12	∞	1.90	—	—
13	-15.278	2.70	1.84666	23.8
14	10.546	3.80	1.64769	33.8
15	-47.414	0.10	—	—
16	24.119	4.72	1.69680	55.5
17	-18.574	0.10	—	—
18	10.045	3.01	1.77250	49.6
19	19.703	5.36	—	—
20	∞	3.50	1.49782	66.8
21	∞	—	—	—

Enomoto-Ito patent / example 5

FIG. 17

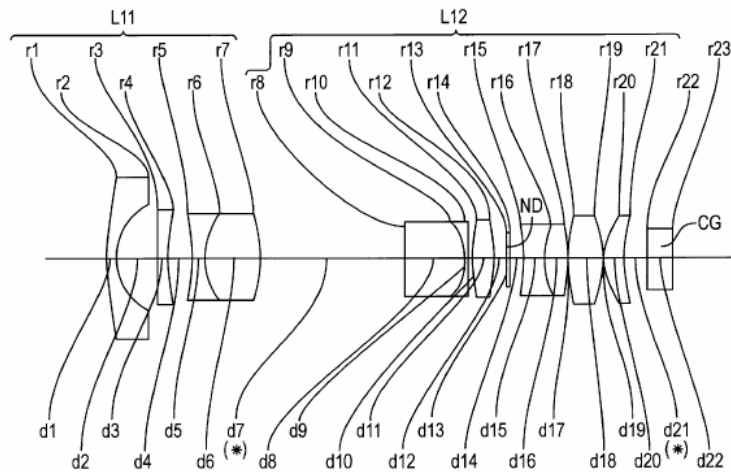

(Embodiment 5)

F	2.22	2.63	3.11
F_{NO}	1.4	1.4	1.4
W	90.0°	90.0°	82.1°
Y	2.47	2.94	3.40
Wa (Ya = 1.8)	51.2°	41.7°	34.5°
Wb (Yb = 2.4)	81.7°	59.6°	47.9°
Wc (Yc = 3.0)	—	—	64.9°

TABLE 5

$$f_B = D_{21} + D_{22}/N_{22} = 4.90 - 5.57 - 6.37 \text{ (reduced distance)}$$

Surface No.	R	D	N_d	v_d
1	85.090	1.01	1.77250	49.6
2	10.294	5.70	—	—
3	-61.646	1.73	1.60311	60.7
4	38.745	2.91	—	—
5	-12.183	1.93	1.80400	46.6
6	8.855	7.06	1.74077	27.8
7	-19.820	18.97 - 11.19 - 4.70	—	—
8	292.729	7.60	1.70154	41.2
9	-10.773	1.20	1.84666	23.8
10	-20.276	0.10	—	—
11	14.884	2.51	1.77250	49.6
12	174.157	1.90	—	—
13	∞	0.50	1.51633	64.1
14	∞	1.90	—	—
15	-19.479	2.70	1.84666	23.8
16	7.755	3.80	1.64769	33.8
17	-41.543	0.10	—	—
18	54.109	4.72	1.69680	55.5
19	-17.172	0.10	—	—
20	12.827	3.01	1.77250	49.6
21	65.826	2.56 - 3.23 - 4.03	—	—
22	∞	3.50	1.49782	66.8
23	∞	—	—	—

An economical triplet for over-head projectors (US5596455)



US005596455A

United States Patent [19]
Eckhardt

[11] **Patent Number:** **5,596,455**
[45] **Date of Patent:** **Jan. 21, 1997**

[54] **FIXED-FOCUS TRIPLET PROJECTION LENS FOR OVERHEAD PROJECTORS**
[75] **Inventor:** **Stephen K. Eckhardt, Austin, Tex.**
[73] **Assignee:** **Minnesota Mining and Manufacturing Company, St. Paul, Minn.**

3,194,116 7/1965 Altman .
3,202,051 8/1965 Bechtold .
3,237,520 3/1966 Rickless et al. .
3,359,057 12/1967 Ackroyd .
3,438,696 4/1969 Ruben .
3,438,697 4/1969 Melech .

(List continued on next page.)

FOREIGN PATENT DOCUMENTS

[21] **Appl. No.:** **496,773**
[22] **Filed:** **Jun. 29, 1995**
[51] **Int. Cl.⁵** **G02B 9/14**
[52] **U.S. Cl.** **359/789; 359/785**
[58] **Field of Search** **359/789, 785, 359/649, 651**

1037274 9/1953 France 17/3
287089 1/1913 Germany .
434759 12/1924 Germany .
4118146C1 9/1992 Germany G02B 13/00
22607 of 1895 United Kingdom .
15107 of 1895 United Kingdom .
4714 of 1911 United Kingdom .
155640 12/1920 United Kingdom .
422246 1/1935 United Kingdom .
532950 2/1941 United Kingdom .
601649 5/1948 United Kingdom .
612757 10/1948 United Kingdom .

OTHER PUBLICATIONS

"Modern Optical Engineering: The Design of Optical Systems" by Warren J. Smith Copyright 1990 by McGraw-Hill, Inc., pp. 384-391 no month.
"Lens Design Fundamentals" by Rudolf Kingslake, Copyright 1978 by Academic Press, Inc., 111 Fifth Avenue, New York, New York 10003, pp. 286-295 no month.

Primary Examiner—David P. Porta
Assistant Examiner—Richard Hanig
Attorney, Agent, or Firm—Gary L. Griswold; Walter N. Kirn; G. F. Chernivce

[57] **ABSTRACT**

A Cooke triplet projection lens for use in overhead projectors comprises two outer positive elements of an ophthalmic crown glass and one inner negative element of a light flint glass. The crown glass has a refractive index of roughly 1.523 and an Abbe value of 58.5. The flint has an index of less than 1.573 and an Abbe value of between 43 and 53. One of the positive elements is biconvex; the other is meniscus.

20 Claims, 2 Drawing Sheets

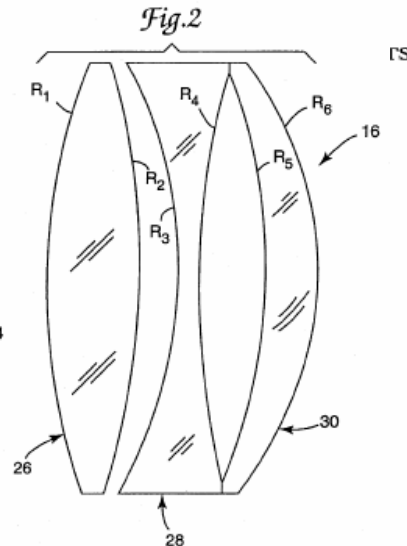
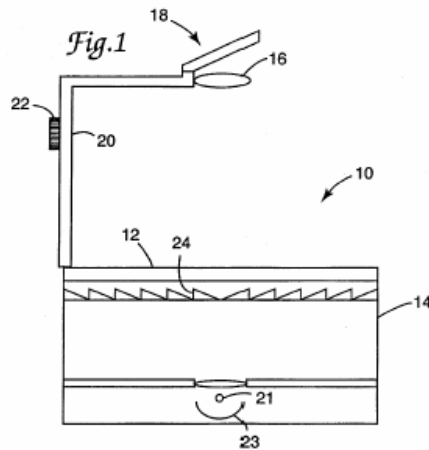

Fast double-Gauss lens (US5920436)



US005920436A

United States Patent [19]
Kitahara

[11] **Patent Number:** **5,920,436**
[45] **Date of Patent:** **Jul. 6, 1999**

[54] **LARGE-APERTURE LENS FOR LOW-ILLUMINANCE IMAGING**

[75] Inventor: **You Kitahara**, Omiya, Japan

[73] Assignee: **Fuji Photo Optical Co., Ltd.**, Saitama, Japan

[21] Appl. No.: **09/047,407**

[22] Filed: **Mar. 25, 1998**

[30] **Foreign Application Priority Data**

Mar. 27, 1997 [JP] Japan 9-094646

[51] **Int. Cl.⁵** **G02B 13/04; G02B 9/64**

[52] **U.S. Cl.** **359/751; 359/749; 359/754; 359/755**

[58] **Field of Search** **359/749, 750, 359/751, 752, 753, 754, 755**

[56] **References Cited**

U.S. PATENT DOCUMENTS

3,992,085	11/1976	Momiyama	359/750
4,061,421	12/1977	Nakagawa	359/749
5,623,371	4/1997	Hankawa	359/749
5,796,529	8/1998	Park	359/751

Attorney, Agent, or Firm—Ronald R. Snider; Snider & Chao, LLP

[57] **ABSTRACT**

In a large-aperture lens for low-illuminance imaging, a Gauss type lens configuration is employed, and a negative lens having a predetermined refracting power is inserted in front of the front-side cemented lens, whereby back focus is secured while compactness is attained, without using an aspherical lens. Successively disposed from the object side are a biconvex lens L_1 , a positive meniscus lens L_2 having a convex surface directed onto the object side, a negative lens L_3 having a concave surface with a stronger curvature directed onto the image side, a positive meniscus lens L_4 (cemented with lens L_3) having a convex surface directed onto the object side, a negative meniscus lens L_5 having a concave surface directed onto the image side, a biconcave lens L_6 (cemented with lens L_7) having a surface with a stronger curvature directed onto the object side, biconvex lenses L_7 and L_8 each having a surface with a stronger curvature directed onto the image side, and a positive meniscus lens L_9 having a convex surface directed onto the object side. Assuming that the focal length of the whole system is f and the focal length of the third lens is f_3 , the conditional expression of $0.35 < f/|f_3| < 0.56$ is satisfied.

Primary Examiner—Scott J. Sugarman

4 Claims, 6 Drawing Sheets

Total FOV=40 degrees
F-number: f/0.85
(No aspherical lens)

Intended for fluoresces observation of biological Specimens
1. Color correction is necessary

Kitahara's patent /example 1

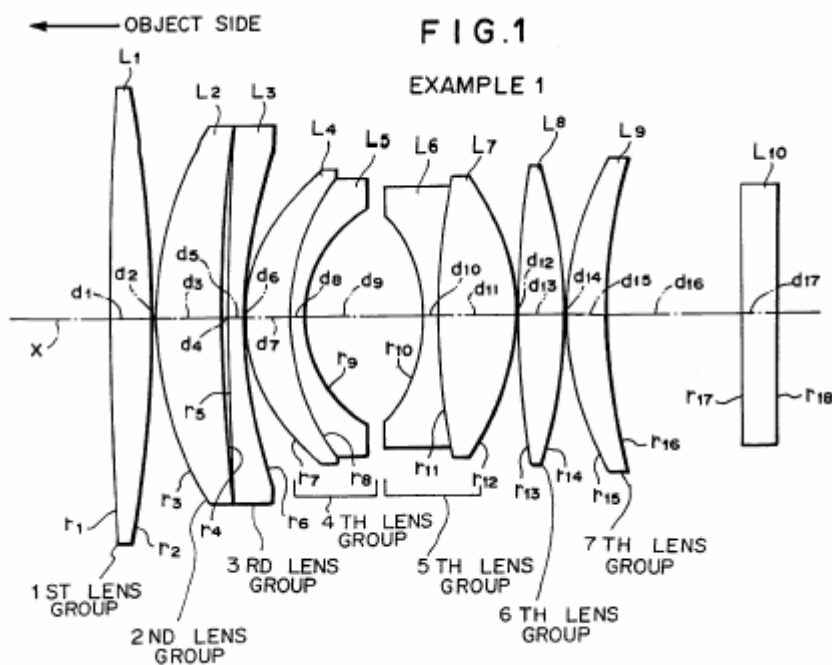

TABLE 1

Surface	r	d	N	v
1	268.23	3.20	1.78500	43.7
2	-95.04	0.30		
3	26.75	4.90	1.83500	42.7
4	103.28	0.46		
5	220.97	1.25	1.78472	25.7
6	41.65	0.10		
7	13.59	3.25	1.83500	42.7
8	18.12	1.00	1.64769	33.9
9	9.29	9.00		
10	-11.37	1.00	1.84666	23.9
11	53.35	5.85	1.88300	40.9
12	-17.18	0.20		
13	70.44	3.55	1.88300	40.9
14	-35.35	0.10		
15	23.33	2.90	1.83500	42.7
16	44.83	10.00		
17	∞	2.65	1.51633	64.1
18	∞			

F = 24.0

Fno = 1:0.85

$2\omega = 40.0^\circ$

conjugate length = 300 mm

back focus = focal length \times 0.419 (10.1 mm)

Kitahara's patent /example 2

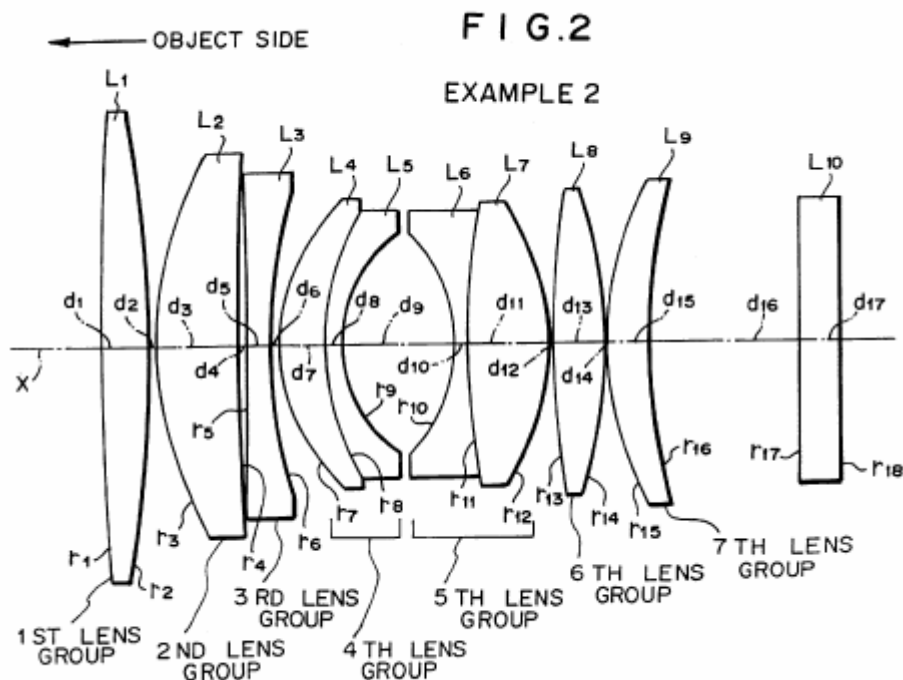

TABLE 2

Surface	r	d	N	v
1	241.35	3.20	1.81035	41.5
2	-88.84	0.47		
3	26.71	5.43	1.85142	41.2
4	155.19	0.55		
5	-3751.43	1.62	1.79049	25.8
6	37.25	0.65		
7	13.43	3.00	1.85507	40.8
8	18.18	1.00	1.66761	32.5
9	9.31	7.49		
10	-11.41	1.00	1.84666	23.9
11	52.74	5.50	1.88300	40.9
12	-17.47	0.28		
13	68.25	3.55	1.88300	40.9
14	-33.79	0.10		
15	23.23	2.81	1.84180	42.1
16	45.40	10.00		
17	∞	2.65	1.51633	64.1
18	∞			

F = 23.9

Fno = 1:0.85

$2\omega = 39.8^\circ$

conjugate length = 300 mm

back focus = focal length \times 0.419 (10.0 mm)

Kitahara's patent / example 3

TABLE 3

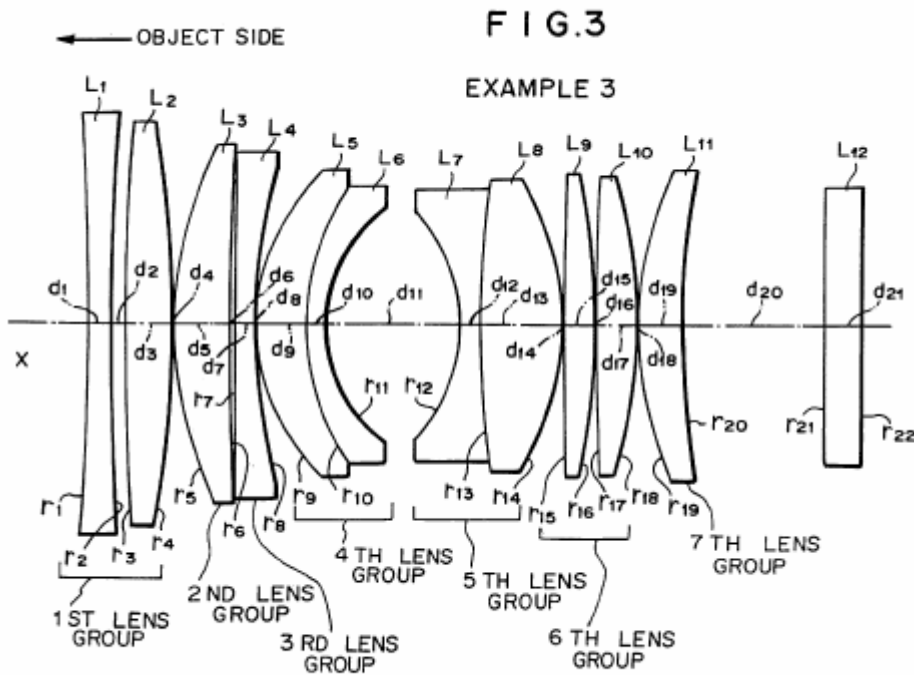

Surface	r	d	N	v
1	-213.50	1.52	1.71700	47.9
2	190.81	1.09		
3	215.48	3.43	1.88300	40.9
4	-74.87	0.13		
5	30.52	3.73	1.88300	40.9
6	266.63	0.25		
7	1153.92	1.50	1.74000	28.2
8	44.59	0.10		
9	15.11	3.50	1.88300	40.9
10	18.29	1.45	1.68893	31.1
11	10.62	9.23		
12	-11.92	1.50	1.84666	23.9
13	73.06	5.85	1.83500	42.7
14	-19.68	0.10		
15	529.52	2.11	1.83500	42.7
16	-55.97	0.10		
17	246.07	2.80	1.80235	46.7
18	-37.60	0.10		
19	25.84	3.03	1.80235	46.7
20	61.04	10.00		
21	∞	2.65	1.51633	64.1
22	∞			

F = 23.9

Fno = 1:0.85

$2\omega = 41.4^\circ$

conjugate length = 300 mm

back focus = focal length \times 0.466 (11.1 mm)

Low-distortion fingerprint detection system (US5900993)



US005900993A

United States Patent [19]
Betensky

[11] **Patent Number:** **5,900,993**
[45] **Date of Patent:** **May 4, 1999**

[54] **LENS SYSTEMS FOR USE IN FINGERPRINT DETECTION**

[75] **Inventor:** Ellis Betensky, Toronto, Canada

[73] **Assignee:** Cross Check Corporation, North Palm Beach, Fla.

[21] **Appl. No.:** 08/854,157

[22] **Filed:** May 9, 1997

[51] **Int. Cl.⁶** G02B 13/18

[52] **U.S. Cl.** 359/710; 356/71

[58] **Field of Search** 359/663, 710; 356/71

[56] **References Cited**

U.S. PATENT DOCUMENTS

2,500,017	3/1950	Altman	359/710
3,200,701	8/1965	White .	
3,482,498	12/1969	Becker .	
3,527,535	9/1970	Monroe .	
3,947,128	3/1976	Weinberger et al. .	
3,968,476	7/1976	McMahon .	
4,063,226	12/1977	Kozma et al.	356/125
4,210,899	7/1980	Swonger et al. .	

FOREIGN PATENT DOCUMENTS

2 089 545 6/1982 United Kingdom .
WO 92/11608 7/1992 WIPO .

OTHER PUBLICATIONS

Bahuguna et al., "Prism fingerprint sensor that uses a holographic optical element," *Applied Optics*, vol. 35, pp. 5242-5245, Sep. 1996.

Hebert, Robert T., "Off-axis optical elements in integrated, injection-molded assemblies," *SPIE*, vol. 2600, pp. 129-134, Dec. 1995.

Stoltzmann et al., "Versatile anamorphic electronic fingerprinting: design and manufacturing considerations," *SPIE*, vol. 2537, pp. 105-116, Aug. 1995.

Primary Examiner—Georgia Y. Epps
Assistant Examiner—Michael A. Lucas
Attorney, Agent, or Firm—Maurice M. Klee

[57] **ABSTRACT**

Lens systems for use in fingerprint detection systems employing frustrated total internal reflection are provided. The systems include an aperture stop and three lens units. The first lens unit has a positive power, is located on the object side of the aperture stop, and forms a telecentric pupil for the lens system. The second lens unit has a positive power, is located on the image side of the first lens unit, and forms a real image of the object. In certain embodiments, the third lens unit is located between the first and second lens units and has substantially afocal cylindrical power. In other embodiments, the third lens unit serves to correct the field curvature of the image contributed by the first and second lens units.

18 Claims, 9 Drawing Sheets

High contrast
is needed in
such system.

Using Total
internal
reflection
But poor
imaging
quality has to
be recovered.

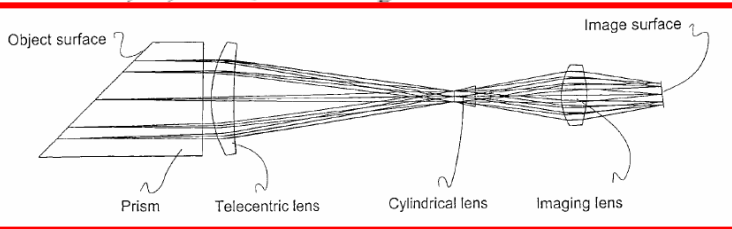

Betensky's patent / example 1

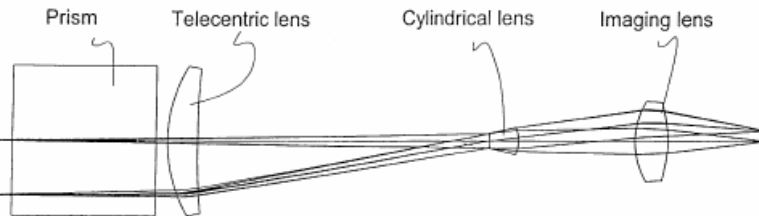
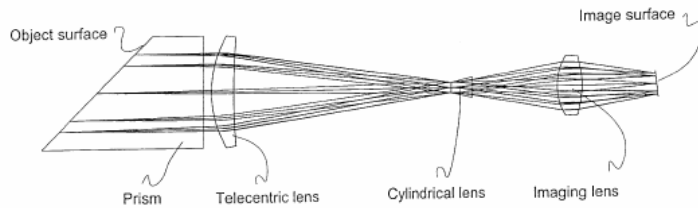
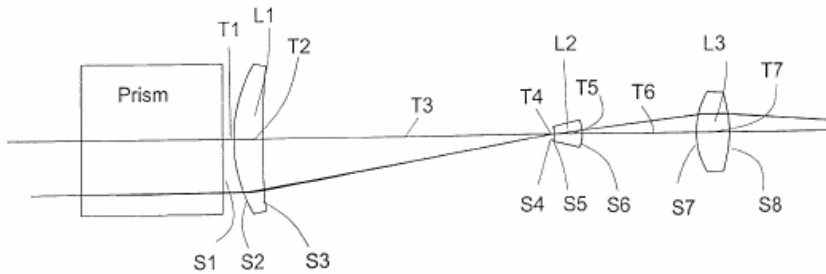

TABLE 1

SYSTEM DATA

Total Track	107.593
Working F/#	5.10882
Obj. Space N.A.	0.022
Maximum Field	13.1
Primary Wave	0.650000 microns

SURFACE DATA SUMMARY

Type	Radius	Thickness	Glass	Diameter	Conic
1 TILTSURF	—	25	BK7	26.20408	—
2 STANDARD	Infinity	2		26.09679	0
3 STANDARD	25.70843	5.2	ACRYLIC	26.04222	0
4 EVENASPH	231.1318	51.70056		25.2033	0
5 STO STANDARD	Infinity	0		2.487769	0
6 TOROIDAL	Infinity	5	BK7	2.556231	0
7 TOROIDAL	Infinity	20.27059		4.734597	0
8 STANDARD	13.64298	5.8	ACRYLIC	13.95049	0
9 EVENASPH	-18.10472	17.62166		13.58516	-5.661331
10 IMA TILTSURF	—	0		6.167979	—

SURFACE DATA DETAIL

Object Surface	Tilted 45 degrees
Image Surface	Tilted 6.5 degrees

ASPHERICAL SURFACE DATA

Surf.	D	E	F	G	H	I
3	1.123047E-5	-1.738811E-8				
8	3.954257E-5	1.31374E-7	4.264235E-8	-2.068281E-9	4.132821E-11	-3.018667E-13
	Surface 5	TOROIDAL	Radius of revolution.		-3.967406	
	Surface 6	TOROIDAL	Radius of revolution.		-6.046119	

Betensky's patent / example 2

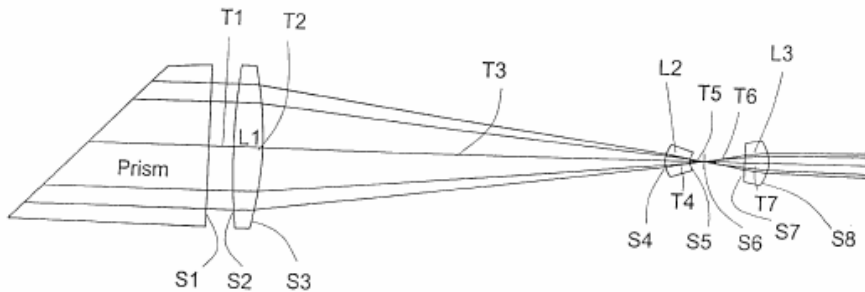

SYSTEM DATA

Total Track	135.915
Working F/#	4.36037
Maximum Field	15.89
Primary Wave	0.650000 microns

SURFACE DATA SUMMARY

Surf	Type	Radius	Thickness	Glass	Diameter	Conic
OBJ	TILT-SURF	—	25	BK7	31.78003	—
1	STANDARD	Infinity	5.190437		32.86197	0
2	STANDARD	136.3678	6	ACRYLIC	33.13347	0
3	STANDARD	-66.82787	83.18716		32.97939	-3.393647

TABLE 2-continued

4	STANDARD	5.478497	5	K10	6.598144	0
5	STANDARD	3.073549	2.831673		3.660189	0
STO	STANDARD	Infinity	8.328321		3.099801	0
7	STANDARD	250.2192	5	ACRYLIC	7.829303	0
8	EVEN-ASPH	-9.070955	20.37725		9.067809	0
IMA	TILT-SURF	—	0		6.134792	—

SURFACE DATA DETAIL

Object Surface Tilted 45 degrees
Image Surface Tilted 7.21 degrees

Surface 8 Aspherical Coefficients for powers of r
 r^2 : -0.02235599; r^4 : 5.636344E-5; r^6 : 9.350753E-6; r^8 : -1.163031E-6;
 r^{10} : 8.182924E-8; r^{12} : -2.915787E-9; r^{14} : 4.1623E-11

Betensky's patent / example 3

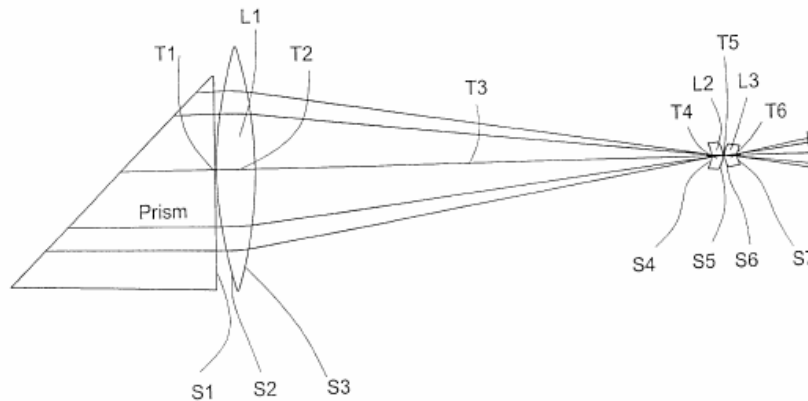

TABLE 3

SYSTEM DATA

Total Track	70
Working F/#	4.30765
Obj. Space N.A.	0.022
Maximum Field	13.102
Primary Wave	0.650000 microns

SURFACE DATA SUMMARY

Surf	Type	Radius	Thickness	Glass	Diameter	Conic
OBJ	TILTSURF	—	11	BK7	26.20408	—
1	STANDARD	Infinity	0.2		27.90575	0
2	EVENASPH	39.89135	4.473029	ACRYLIC	28.21343	-5.826537
3	STANDARD	-48.78966	53.56381		28.19267	0
4	STANDARD	-2.906349	1.339289	ACRYLIC	2.914914	0
5	EVENASPH	-2.656021	0.2		3.107117	0
STO	STANDARD	2.184049	1.523577	ACRYLIC	2.657442	0
7	EVENASPH	2.191862	8.700297		2.213909	0
IMA	TILTSURF	—	0		4.932881	—

SURFACE DATA DETAIL

Object Surface	Tilted 45 degrees
Image Surface	Tilted 6.8 degrees

ASPHERICAL SURFACE DATA

Surf.	D	E	F	G	H	I
2	-1.676925E-6	5.368215E-9				
5	0.004577377	0.0007814665	-0.0004157694	0.0001039365		
7	0.004622665	0.008402386	-0.005275569	-0.0002330626	0.006666924	-0.003251713

Betensky's patent / example 4

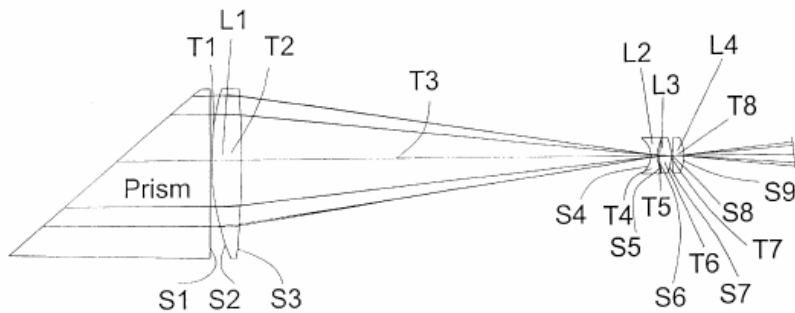

TABLE 4

SYSTEM DATA	
Total Track	70
Working F/#	4.31084
Obj. Space N.A.	0.022
Maximum Field	13.102
Primary Wave	0.650000 microns

SURFACE DATA SUMMARY						
Surf	Type	Radius	Thickness	Glass	Diameter	Conic
OBJ	TILTSURF	—	11	BK7	26.20408	—
1	STANDARD	Infinity	0.2		27.48681	0
2	STANDARD	43.31	3.5	SF1	27.72874	0
3	STANDARD	-171.85	49.17685		27.58105	0
4	STANDARD	-3.234051	0.8	BK7	5	0
5	STANDARD	6.522	0.25		5	0
6	STANDARD	12.474	1.4	SF1	5	0
7	STANDARD	-7.133	0.2		5	0
STO	STANDARD	Infinity	1.3	SF6	5	0
9	STANDARD	-6.522	13.17316		5	0
IMA	TILTSURF	—	0		4.9432	—

SURFACE DATA DETAIL
Object Surface: Tilted 45 degrees
Image Surface: Tilted 6.2 degrees

Betensky's patent /example 5

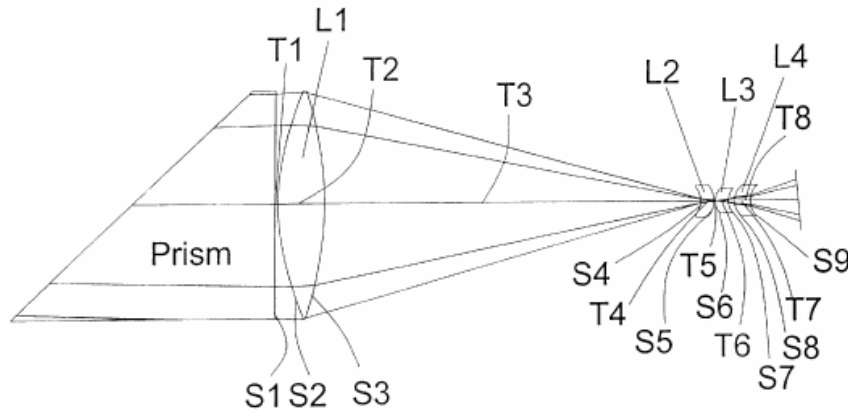

TABLE 5

SYSTEM DATA

Total Track	40.1763
Working F/#	4.33983
Obj. Space N.A.	0.022
Maximum Field	13.102
Primary Wave	0.650000 microns

SURFACE DATA SUMMARY

Surf	Type	Radius	Thickness	Glass	Diameter	Conic
OBJ	TILT-SURF	—	11	BK7	26.20408	—
1	STANDARD	Infinity	0.2		22	0
2	EVEN-ASPH	20.65035	3.5	ACRYLIC	22	0
3	STANDARD	-31.72422	29.02133		22	0
4	EVEN-ASPH	-1.70406	1	ACRYLIC	2.6	0
5	STANDARD	-2.198759	0.1		2.6	0
STO	STANDARD	1.547474	1	ACRYLIC	2	0
7	EVEN-ASPH	1.829054	0.4824209		2	0
8	STANDARD	1.755336	1.177711	ACRYLIC	2.6	0
9	EVEN-ASPH	2.020989	3.694845		2.6	0
IMA	TILT-SURF	—	0		4.976063	—

SURFACE DATA DETAIL

Object Surface: Tilted 45 degrees
Image Surface: Tilted 5.02 degrees

ASPHERICAL SURFACE DATA

Surf.	D	E	F	G
2	-4.629466E-5	-4.629466E-5		
4	0.01786009	0.0319493	-0.05570782	0.03130791
7	0.06001557	0.03785613	-0.03016861	0.03552276
9	0.01319803	0.001277422	0.001882929	0.001614795

Results of Search in 1790 to present db for:

REF/5900993: 7 patents.

Hits: 1 through 7 out of 7

Jump To

Only to 2003

Refine Search

ref/5900993

PAT. NO. Title

- 1 [6,485,145](#) [Optical system for display panel](#)
- 2 [6,476,973](#) [Compound surface to aid in the fabrication of a lens with a plano surface](#)
- 3 [6,272,562](#) [Access control unit interface](#)
- 4 [6,263,090](#) [Code reader fingerprint scanner](#)
- 5 [6,178,255](#) [Individualized fingerprint scanner](#)
- 6 [6,127,674](#) [Uneven-surface data detection apparatus](#)
- 7 [6,115,484](#) [Economical skin-pattern-acquisition and analysis apparatus for access control, systems controlled thereby](#)

Some current patents

(12) **United States Patent**
Mihara

(10) **Patent No.:** **US 6,323,892 B1**
(45) **Date of Patent:** **Nov. 27, 2001**

(54) **DISPLAY AND CAMERA DEVICE FOR**
VIDEOPHONE AND VIDEOPHONE
APPARATUS

(75) Inventor: **Takashi Mihara, Iruma (JP)**

(73) Assignee: **Olympus Optical Co., Ltd., Tokyo (JP)**

(*) Notice: Subject to any disclaimer, the term of this patent is extended or adjusted under 35 U.S.C. 154(b) by 0 days.

(21) Appl. No.: **09/363,217**

(22) Filed: **Jul. 29, 1999**

(30) **Foreign Application Priority Data**

Aug. 4, 1998 (JP) 10-220516

(51) **Int. Cl.**⁷ **H04N 7/14**

(52) **U.S. Cl.** **348/14.01; 348/14.08;**
348/14.16

(58) **Field of Search** 348/14, 15, 20,
348/335, 340; 404/235; 359/364, 833, 868,
869

(56) **References Cited**

U.S. PATENT DOCUMENTS

5,317,405 * 5/1994 Kuriki et al. 348/20
5,730,518 * 3/1998 Kashima et al. 362/31
5,815,196 * 9/1998 Alshawi 704/235

FOREIGN PATENT DOCUMENTS

402194786A * 8/1990 (JP) H04N/7/14

404310053A * 11/1992 (JP) H04M/11/06
405064183A * 3/1993 (JP) H04N/7/14
405292491A * 11/1993 (JP) H04N/7/14
6-22308 1/1994 (JP) .
406133308A * 5/1994 (JP) H04N/7,
408140143A * 5/1996 (JP) H04Q/7,
408149444A * 6/1996 (JP) H04N/7,
4083400520A * 12/1996 (JP) H04N/7,
9-166760 6/1997 (JP) .
410191288A * 7/1998 (JP) H04N/7,
63-252084 10/1998 (JP) .

* cited by examiner

Primary Examiner—Curtis Kuntz

Assistant Examiner—Melur Ramakrishnaiah

(74) *Attorney, Agent, or Firm*—Frishauf, Holtz, Goodm;
Langer & Chick, P.C.

(57) **ABSTRACT**

A display and camera device for a videophone comprises a liquid crystal display for displaying a picture, a camera such as a CCD sensor or a CMOS sensor, a free-form surface prism, and a prism for guiding light to the camera. The free-form surface prism has a concave reflector for optically enlarging a picture displayed on the display. A beam splitter is provided on a bonded surface between the free-form surface prism and the prism. The beam splitter is designed to reflect some of light beams from the display toward the reflector and transmit some of light beams from the reflector. A camera-system optical path extending from the camera is aligned with a display-system optical path extending from the display within the free-form surface prism and the outside space.

29 Claims, 6 Drawing Sheets

Camera lens

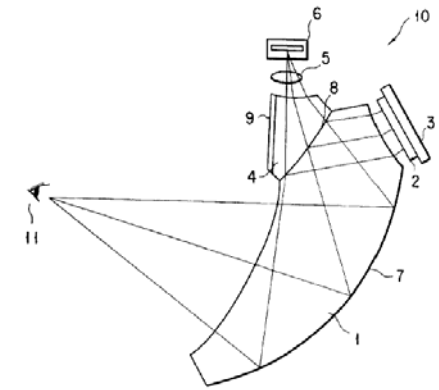

Free-form optics

(No lens data included in this patent)

Conclusions

- Lens patents usually have lens data files
 - But, often some key points (parameters) missed
 - The retrieval needs some skills
 - A good test platform is most crucial
 - modification with optimization is critical
- Simple extensions of application
 - Scaling
 - Materials replacement
 - Image-plane Resizing
 - Throughput changing
 - ...
- New applications drive new designs
 - We may have to consider different approaches in optical design but reading patent can enhance your design capability

Homework

- 你的作業是
 - 到google的專利網頁
 - <http://www.google.com/patents>
 - 自選出一個項目
 - 做相關的專利地圖分析
 - 要說明你為何是這樣子選的?
 - 你的專利地圖分析的依據為何?