

FEATURES

High Output Current: 10A
 High Efficiency: 97% - No Heat Sink Required
 High Stability: < 100ppm/°C
 Dual Mode Control: Current and Power or Voltage
 Very Low Noise: < 0.05%
 Zero EMI
 Compact Size: 39×34×8 (mm)
 SMT and DIP Package

APPLICATIONS

Drive diode lasers, heaters & TECs, and can be used as DC-DC voltage converter as well.

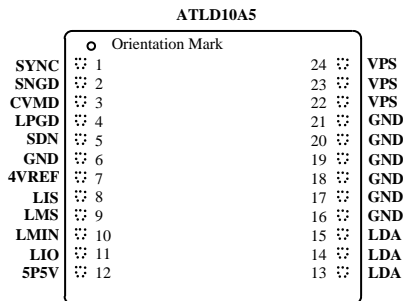

Figure 1 Top View of ATLD10A5

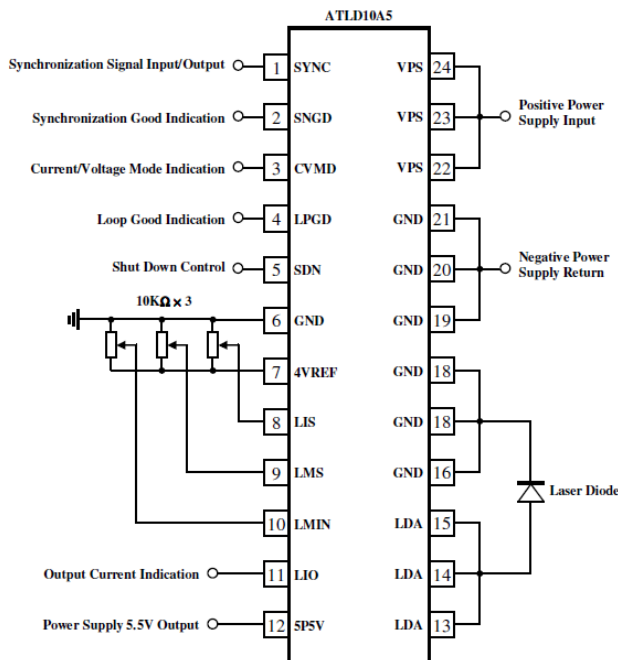

Figure 2 Typical Application Connection

DESCRIPTIONS

The ATLD10A5 is an electronic module designed for driving high current diode lasers with well controlled output current and laser power or voltage. Its efficiency is so high that no heat sink is needed even outputting a 10A current. See Figure 3.



Figure 3 Physical photos of ATLD10A5

The output control has two modes: constant current and constant power or constant voltage. For most applications, constant current is utilized. The constant power or voltage can be used for as a protection tier. For the applications requiring constant power control, the constant current loop can be used as a protection tier. In this way, in case there is a failure in control loop, and other one can still protect valuable laser diode.

The output current is monitored by an analog output voltage linearly, making it convenient for the users to monitor the output current without breaking the output circuit.

This module can also be used as a low noise and well protected DC-DC converter. This is done by setting the controller into constant voltage control and using the current loop as the protection tier.

A loop status pin, LPGD (pin 4) indicates whether the control loop is working properly, i.e., that output parameter equals the set-point parameter. For current mode control, the output current equals the set-point current; under power mode, the output power equals the set-point voltage; under voltage mode, the output voltage equals the set-point voltage.

The constant power or voltage is realized by feeding the measured signal into the laser monitor pin, LMIN (pin 10) and the set-point value for the signal is set by the LMS pin (pin 9).

It is worth noting that the controller's output noise is located in two spectrums:

- A. Low frequency. It ranges from DC to 10Hz.
- B. High frequency. It is the multiple harmonics of the switching frequency of the PWM (Pulse Width Modulation) output stage: 500KHz.



The ATLD10A5 comes with a highly stable low noise 4V reference voltage which can be used for setting the output current, the current limit, the output voltage and the voltage limit. It can also be used as the reference voltage for external ADCs and/or DACs.

The controller is housed inside a 6 sided metal enclosure, which blocks EMIs from reaching out and disturbing other nearby electronics and, at the same time, prevents the module from being interfered by EMIs from other electronics.

A 5.5V 100mA power supply is provided for powering external electronic circuits (if there is any).

The controller has 2 versions for mounting on the PCB: through hole mount or surface mount.

Please be aware of this: the SMT version cannot go through the reflow even. It must be soldered manually.

Figure 1 shows the pin names and locations. Figure 2 illustrates a typical application connection.

PIN DESCRIPTIONS

Pin #	Pin Name	Signal Type	Description	Note
1	SYNC	Digital Input/Output	Synchronization input/output. It is optional that this pin can be connected to an external clock signal with which the controller will be switching at the same frequency, eliminating beating interferences. This pin can also be used as a clock signal for synchronizing other switch mode electronics. When using multiple ATLD10A5 controllers, connect all the SYNCs of these controllers together. All of them will be switching at one frequency which will be the highest one among all the controllers.	
2	SNGD	Digital Output	Synchronization good indication. When the internal switching frequency matches the clock frequency at the SYNC pin, this pin is pulled high (3V to 5V); otherwise, this pin is pulled low.	
3	CVMD	Digital Output	Mode indication. It is pulled high when the controller is working at the current mode, other wise, when it is under voltage mode, this pin is pulled low.	
4	LPGD	Digital Output	Loop good indication. When the controller is working properly, this pin is pulled high. Otherwise, it is pulled low.	
5	SDN	Analog/Digital Input	Standby and Shut-down. Negative logic. It is internally pulled up by a 100K resistor to 5.5V. Pulling it down between 5V to 1V put the controller into Standby mode; between 0.8V to 0V putting the device into Shut-down mode.	
6	GND	Ground	Signal ground. Connect signal ground to this pin.	
7	4VREF	Analog output	Voltage reference output, 4V. To be used for setting the output current, the current limit, the output voltage and the output voltage limit. It can also be used by external ADCs and DACs if they are used for monitoring and/or setting the output parameters.	
8	LIS	Analog input	Current set. Voltage input for setting the output current. Setting it between 0 to 4V sets the output current between 0 to 10A linearly. The output current will be regulated to the value set.	
9	LMS	Analog Input	Laser monitor set. The voltage input at this pin will force the controller to follow the voltage input fed into the LMIN pin (#10), provided the output current is less than the current set by the LIS pin.	
10	LMIN	Analog Input	Laser monitor input. This pin can be fed by analog signals for monitoring the laser, such as laser voltage or laser power.	
11	LIO	Analog Output	Laser current indication output. An output voltage of 0 to 4V at this pin indicates the output current being 0 to 10A linearly.	
12	5P5V	Power Output	A 5.5V auxiliary power supply output. It can be used for powering external electronic circuits and the maximum output current is 150mA.	



13	LDA	Power output	Positive output terminal to be connected to the load.	
14				
15				
16	GND	Power output	Negative output terminal to be connected to the load.	
17				
18				
19	GND	Power ground	Negative power input to be connected to the return terminal of the power supply.	
20				
21				
22	VPS	Power input	Positive power input to be connected to the positive terminal of the power supply.	
23				
24				

**Measured at: Iout=10A and Vout=10V.

SPECIFICATIONS

Power supply voltage:	4.5V to 16V
Maximum output current:	10A
Maximum output voltage:	0V to 0.95×VPS*
Current set voltage:	0 to 4V
Current limit set voltage:	0 to 4V
Current monitor voltage:	0 to 4V
Voltage set voltage:	0 to 4V
Voltage limit set voltage:	0 to 4V
Output current stability:	<200ppm/°C
Output ripple voltage:	<± 5mV
Output current set accuracy:	<± 5mA
Current limit set accuracy:	<± 0.5A
Output current noise:	<± 0.5mA
Output voltage set accuracy:	<± 50mV
Voltage limit set accuracy:	<± 50mV
Output power supply voltage:	5.5V ± 0.1V
Output power supply current:	0 to 150mA
Synchronization input range:	0 to 5V
Synchronization input threshold:	0.8V
Minimum SNI pulse width:	100nS
Free-run switching frequency:	500KHz ± 10KHz
Synchronization frequency range:	520KHz to 600KHz
Synchronization output range:	0 to 5V
Synchronization output impedance:	1KΩ
Loop good output impedance:	100Ω
Shut down pull up resistance:	100K
Soft-start rise time:	100mS
Efficiency*:	97%
Max. heat generation:	3W
Max. temperature rise:	25°C
Operating temperature:	-10°C to 85°C

*VPS: power supply input voltage.

APPLICATION GUIDE

1. Setting to constant current mode

When driving a load in current mode, such as a laser diode, configure the controller to work under the current mode, while using the output voltage and the voltage limit setting as protection mechanism. This is the way to do it:

- A. Connect LMIN to the LDA pin.
- B. Set the LMS pin at the voltage allowed for the laser. For example, if the laser can take at most 4V, set the LMS at 4V.
- C. If the maxim output voltage exceeds 15V, use a resistor divider circuit to divide the LDA pin voltage and send the divided signal to the LMIN pin.

The load is now to be driven under constant current mode and the CVMD pin (# 3) will output a voltage of about 5.5V. The output current will be controlled by the current set pin LIS. In case there is one component fails in the controller and the output current exceeds the current limit, the voltage limit control circuit takes over the control the CVMD pin will be pulled low.

The relationship between the input voltage on the LIS pin and the output current is:

$$I_{\text{output}} = 10 \cdot (LIS - 0.4V) / 3.696V \text{ (A)},$$

I_output is the output current and the LIS is the voltage on the LIS pin.

2. Setting to constant voltage mode

When driving a voltage load, such as using the controller as a power supply (DC-DC converter), configure the controller to work under the constant voltage mode, while using the current control loop as a protection mechanisms. This is the way:

- A. Connect the LMIN pin (#10) to LDA.
- B. Set the LMS pin (#9) to the voltage desired.



- C. Set the output current limit to about 1.1 times of the maximum output current allowed by setting the LIS pin to a proper voltage.
- D. In case the maximum output voltage exceeds 15V, use a resistor divider network to lower the output voltage at the LDA pin.

The load is now being driven under constant voltage mode and the CVMD pin (# 3) will output a voltage of about 0V. The output voltage will now be controlled by voltage set at the LMS pin. In case there is one component fails in the controller and the output voltage exceeds the current limit set by the LIS pin, controller will be working under the current mode and the CVMD pin will be pulled high.

3. Setting to constant laser power mode

The ATLD10A5 can be used to control the laser to output a constant laser power by using a photo diode (PD) which detects the laser power. This is the way:

- A. Connect the LMIN pin (#10) to the anode of the PD.
- B. Connect the cathode of the PD to 4VREF pin (# 7).
- C. Connect a resistor between LMIN pin and the ground, GND (# 6).
- D. Set the LMS pin (# 9) to a voltage at which the PD will generate corresponding voltage at the LMIN pin.
- E. Set the LIS pin to a voltage at which the controller will output a current that is maximum for laser. The formula for calculating the voltage needed on the LIS pin is:

$$LIS = I_{\text{output}} * 3.696 / 10 \text{ (V)} + 0.4.$$

For example, a 5W constant laser power is needed, at which, the PD will generate 0.1mA current. The resistor between the LMIN and the ground will need to be:

$$R = 4V / 0.1mA = 40.96K\Omega.$$

Now, when the laser output power changes from 0 to 5W power, the voltage at the LMIN pin will change from 0 to 4V. When needing the output power to be 5W, connect LMS pin to 4VREF; when needing, for example, 2.5W, connect LMS

to a 2.048V voltage, which can be obtained by using a resistor divider network to divide the 4VREF voltage by half, or simply using a potentiometer.

4. Modulation

The ATLD10A5 can be modulated by a 1KHz sine wave signal at the LIS or LMS pin.

5. Multi Unit Operation

Multiple ATLD10A5 can be used together. To eliminate the beating interference caused by the switching kick-back noise onto the power supply rail, the SYNC pins (pin 1) of the all the controllers should be connected together. The fastest clock among the controllers will be making all the controllers to switch at the same phase.

When the controllers are synchronized properly, the SNGD (pin 2) will be lift up by an internal resistor of 4.99K to the 5P5V rail.

For single unit operation, the SNGD pin goes high to indicate that the 2 internal switch mode power supplies are synchronized with each other proper.

6. Loop Good Indication

When the control loops, the current or the monitor loop, works properly, the LPGD (pin 2) is pulled up high to the 5P5V rail by a 2.49K resistor.

When the output has a fault, such as over voltage, and/or open or short circuit, the LPGD pin will be pulled low by an open drain FET which has an equivalent resistance of 200Ω.

7. Standby and Shut Down

The SDN is a dual function pin. It is internally pulled up by a 100K resistor to 5.5V, the 5P5V rail. Pulling it down between 5V to 1V put the controller into Standby mode; between 0.8V to 0V putting the device into Shut-down mode.

Under Standby mode, all the circuits, including the voltage reference and the auxiliary power supply 5P5V, keep working, except the output stage for driving the load.

Under Shut-down mode, all the circuits are shut down and the quiescent current is < 10μA.

MOUNTING THE MODULE ON PCB
A. Through hole package

Figure 4 is the side view of this package.

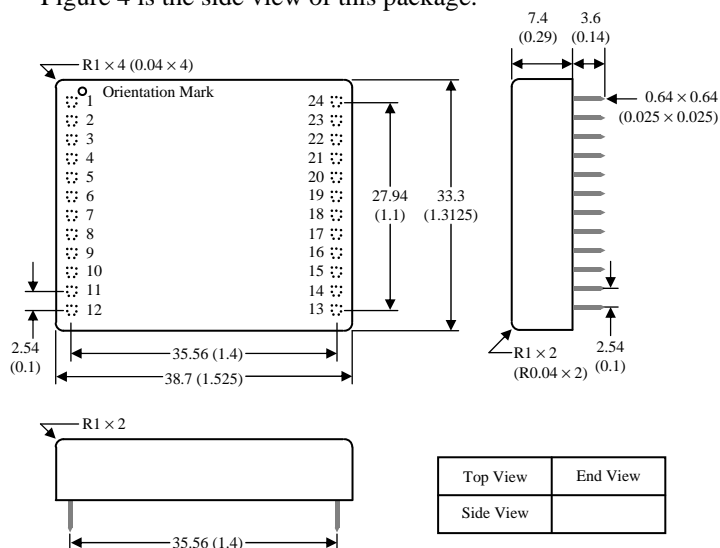

Figure 4 Mechanical Drawings for ATLD10A5-D

It would be better for heat dissipation purpose to lay out a few copper fills as shown in Figure 6. If PCB space permits, place the copper fills on both layers and make them as large as possible. Under a full load, i.e. 10V 10A output, the module needs to dissipate about 3W of power. The temperature rise without any heat sinking is about 25°C.

It should be noted that most of the heat inside the module is internally conducted to pin 13 to 24.

B. SMT package

The ATLD10A5-S has an SMT package. However, being called SMT package, **it cannot be soldered by a reflow oven, and must be soldered manually by a conventional solder iron.**

The mechanical dimensions are shown in Figure 5 and the recommended PCB foot-print is shown in Figure 6, where the copper fills is for helping dissipate the heat from the module. As mentioned above that most of the heat inside the module is internally conducted to pin 13 to 24.

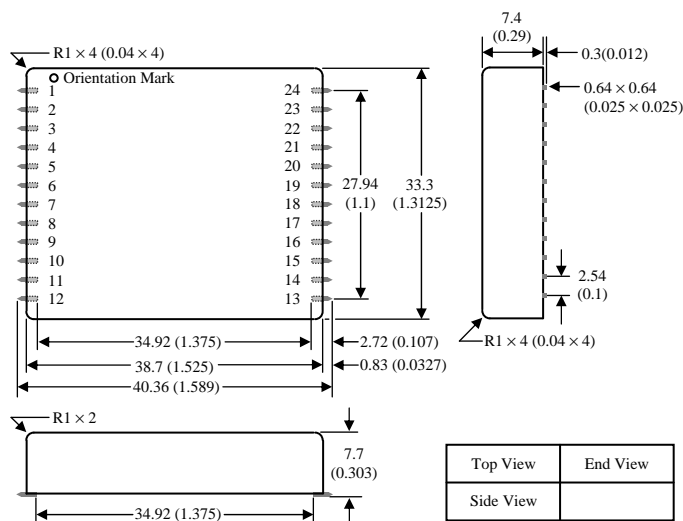

Figure 5 Mechanical Drawings for ATLD10A5-S

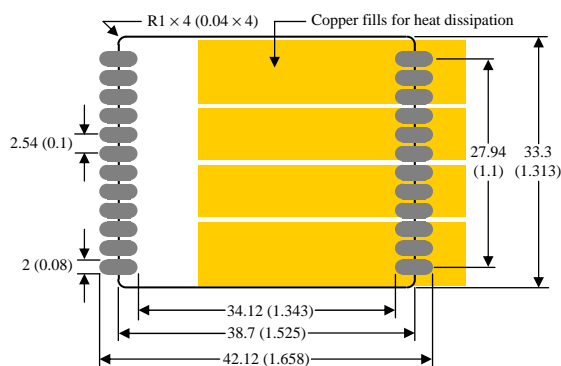

Figure 6 Recommended Foot-print for the SMT Package

Since the metal enclosure is internally connected to ground, make sure that it will not be shorted to other nodes in the PCB.

Use thick and dedicated PCB tracks for connecting the power supply. Connect the 2 power supply input nodes of the module directly to the power supply output of the system. If PCB space permits, use 2 layer tracks in parallel to reduce the resistance and increase the heat dissipation capacity.

When using the power supply output, 5P5V (pin 12), for other electronics, connect the power return node directly to the power ground pins (19 to 21), make sure that the ground node (pin 6) will not carry large current, otherwise, it will cause interferences in setting the output parameters.



ORDERING INFORMATION

A. Package

Part Number	Main Features
ATLD10A5-D	Through Hole Mount.
ATLD10A5-S	Surface Mount*.

* This surface mount package cannot be soldered by reflow oven. It must be soldered manually with a conventional soldering iron.

B. Price

Part Number	1 - 4	5 - 24	25 - 99	100 - 499	≥ 500 PCs	Note
ATLD10A5-D ATLD10A5-S	\$248	\$198	\$150	\$125	\$95	

NOTICE

- ATI warrants performance of its products for one year to the specifications applicable at the time of sale, except for those being damaged by excessive abuse. Products found not meeting the specifications within one year from the date of sale can be exchanged free of charge.
- ATI reserves the right to make changes to its products or to discontinue any product or service without notice, and advise customers to obtain the latest version of relevant information to verify, before placing orders, that information being relied on is current and complete.
- All products are sold subject to the terms and conditions of sale supplied at the time of order acknowledgment, including those pertaining to warranty, patent infringement, and limitation of liability. Testing and other quality control techniques are utilized to the extent ATI deems necessary to support this warranty. Specific testing of all parameters of each device is not necessarily performed, except those mandated by government requirements.
- Customers are responsible for their applications using ATI components. In order to minimize risks associated with the customers' applications, adequate design and operating safeguards must be provided by the customers to minimize inherent or procedural hazards. ATI assumes no liability for applications assistance or customer product design.
- ATI does not warrant or represent that any license, either express or implied, is granted under any patent right, copyright, mask work right, or other intellectual property right of ATI covering or relating to any combination, machine, or process in which such products or services might be or are used. ATI's publication of information regarding any third party's products or services does not constitute ATI's approval, warranty or endorsement thereof.
- IP (Intellectual Property) Ownership: ATI retains the ownership of full rights for special technologies and/or techniques embedded in its products, the designs for mechanics, optics, plus all modifications, improvements, and inventions made by ATI for its products and/or projects.